



# PRICE LIST



Bluvent started its operations in 2013 as a manufacturer that successfully reflects the power of Turkish engineering in the ventilation industry. Bluvent, who wanted to make a difference in the sector since the day it was founded, aimed to offer solutions by combining world standards with cost advantage in technology and innovation. We have created a strong R & D infrastructure in terms of "the most competitive instrument, not the price, but the differences we have created". He took and adopted R & D as a universal culture. From fan to smoke, smoke and pressurized fans, jet fans, subway and tunnel fans to axial fans, EC fans, shelter ventilation fans, roof and duct type fans to bathroom fans.

Turkey in Izmir area with 3,000 m2 production facility's equipment trail consisting of CNC machines. With this equipment track with remote access facilities, every type of plant can respond to different needs and precision cuts in different sizes produce higher quality in all details. The annual production capacity at the Bluvent Production Facility is over 20,000 units.

Every device produced is tested and labeled in the Bluvent Fan Test Laboratory.

With his expertise in fan engineering, Bluvent also included other ventilation system solutions in production planning. Bluvent is presently adding innovations to national and international certification studies every day; BLUVENT have;

- APPlus - 300 ° C / 2h Fire Resistance Certificate
- CE Certificate (EN 12101-3)
- TSE Turkish Standards Institute Certificate of Compliance
- TOBB Domestic Properties Documents
- ISO 9001: 2008 Quality Management System
- ISO 14001: 2004 Environmental Management System
- ISO 10002: 2004 Customer Satisfaction Management System
- ISO 18001: 2007 OHSAS Occupational Health and Safety Management System

certificates. Bluvent has signed a "first" in Turkey with a fan testing laboratory accredited by TÜV-SÜD in accordance with AMCA / ANSI 250-12 and AMCA / ANSI 210-07 standards.

# INDEX

## INDUSTRIAL TYPE FANS

Wall Type Fans



**WOKS Serisi**  
Wall Type Monophase Fans



**AWC Series**  
Wall Type Axial Fans



**AQC Series**  
Wall Type Axial Fans

## INDUSTRIAL FANS

Inline Type Fans



**TURBO Series**  
Inline Mixed-Flow Fans



**YKF Series**  
Inline Type Centrifugal Fans



**AIT Series**  
Inline Type Axial Fans



**AITB Series**  
Bifurcated Inline Type Axial Fans

## INDUSTRIELS FANS

Inline Type Fans



**BOX Series**  
Rectangulars Type Centrifugal Fans



**VKPF Series**  
Rectangulars Type Centrifugal Fans



**PRF Series**  
Rectangulars Type Centrifugal Fans

## INDUSTRIAL FANS

Sound Insulated Fans



**SIT Series**  
Sound Insulated Axial Fans



**SRT Series**  
Sound Insulated Centrifugal Fans

## INDUSTRIAL FANS

Roof Type Fans



**RWD Series**  
Monophases Roof Type Fans



**ARDY Series**  
Roof Type Axial Horizontal Fans



**RDY Series**  
Roof Type Centrifugal Horizontal Fans



**RDV Series**  
Roof Type Centrifugal Vertical Fans

## INDUSTRIAL FANS

Ex-proof Fans

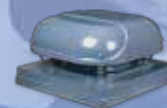

**ARDY-EX Serisi**  
Roof Type Axial Explosion Proof Fans



**AQC-ATEX Serisi**  
Wall Type Axial Explosion Proof Fans



**AIT-ATEX Serisi**  
Inline Type Axial Explosion Proof Fans



PRF-ATEX Series  
Rectangular Type Explosion Proof Fans



RDY - ATEX Series  
Roof Type Centrifugal Explosion Proof Fans

**INDUSTRIAL FANS**  
Centrifugal Direct Drive Fans



P Series  
Polypropylene Centrifugal Fans



CDR Series  
Centrifugal Direct Drive Fans

**INDUSTRIAL FANS**  
Smoke Extraction Fans



AXF Series  
Inline Type Axial  
Smoke Extraction Fans

**INDUSTRIAL FANS**  
Jet Fans



ZXF Series  
Axial Jet Fans



ZXR Series  
Centrifugal Jet Fans

**INDUSTRIAL FANS**  
Heat Recovery Units



CHR Series  
Heat Recovery Units

**ELECTRICAL CONNECTION DIAGRAMS**

Electrical Connection Diagrams



**WOKS Series**  
Wall Type



Wall-mounted axial fans with support and sheet steel rotor. specially designed to obtain high energy efficiency.

FAN

- Sheet metal support base
- Anti-contact protective grille pursuant to standard UNE-EN ISO 12499
- Sheet steel rotor
- Grille-rotor air flow direction

MOTOR

- Class F and B motors with ball bearings and IP54 protection.
- High efficiency external rotor motors.
- Single-phase 230V-50Hz and three-phase 400V-50Hz.
- Operating temperature: -30°C +60°C.

TECHNICAL SPECIFICATIONS

| MODEL    | MAX. FLOW (m <sup>3</sup> /h) | Watt | dBA | AMPER | RPM  | PRICE |
|----------|-------------------------------|------|-----|-------|------|-------|
| WOKS 200 | 850                           | 68   | 63  | 0,30  | 2480 | 120 € |
| WOKS 250 | 1600                          | 106  | 67  | 0,47  | 2480 | 145 € |
| WOKS 300 | 2400                          | 180  | 73  | 0,79  | 2700 | 171 € |
| WOKS 350 | 3100                          | 130  | 64  | 0,58  | 1400 | 198 € |
| WOKS 400 | 3400                          | 160  | 69  | 0,73  | 1430 | 231 € |
| WOKS 450 | 4800                          | 245  | 73  | 0,10  | 1400 | 276 € |

AIR FLOW DATA

| MODEL    | AIR FLOW DATA / PA / (m <sup>3</sup> /h) |      |      |      |      |      |
|----------|------------------------------------------|------|------|------|------|------|
|          | 25                                       | 50   | 70   | 100  | 150  | 200  |
| WOKS 200 | 750                                      | 600  | 420  | 300  | -    | -    |
| WOKS 250 | 1500                                     | 1400 | 1250 | 1100 | -    | -    |
| WOKS 300 | 2350                                     | 2300 | 2000 | 2100 | 1600 | 900  |
| WOKS 350 | 2850                                     | 2600 | 2150 | 1800 | -    | -    |
| WOKS 400 | 3200                                     | 3100 | 2900 | 2700 | 2000 | -    |
| WOKS 450 | 4650                                     | 4500 | 4300 | 4000 | 3500 | 2600 |

# TECHNICAL SPECIFICATIONS

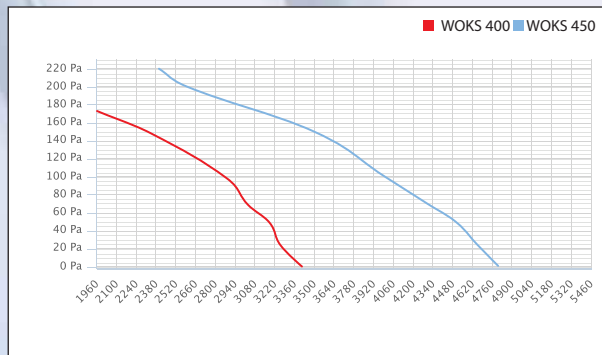
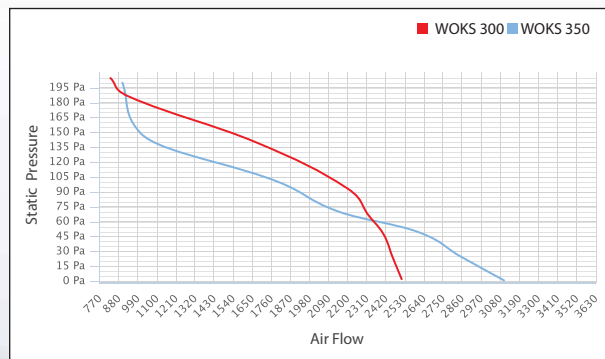
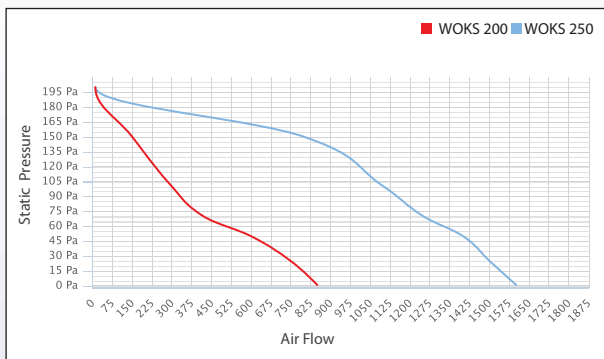

## DIMENSIONS

| MODEL    | DIMENSIONS / mm |     |     |     |
|----------|-----------------|-----|-----|-----|
|          | Ø A             | B   | C   | D   |
| WOKS 200 | 212             | 320 | 70  | 260 |
| WOKS 250 | 262             | 365 | 90  | 315 |
| WOKS 300 | 313             | 430 | 92  | 380 |
| WOKS 350 | 360             | 485 | 88  | 435 |
| WOKS 400 | 408             | 540 | 100 | 490 |
| WOKS 450 | 465             | 575 | 125 | 535 |

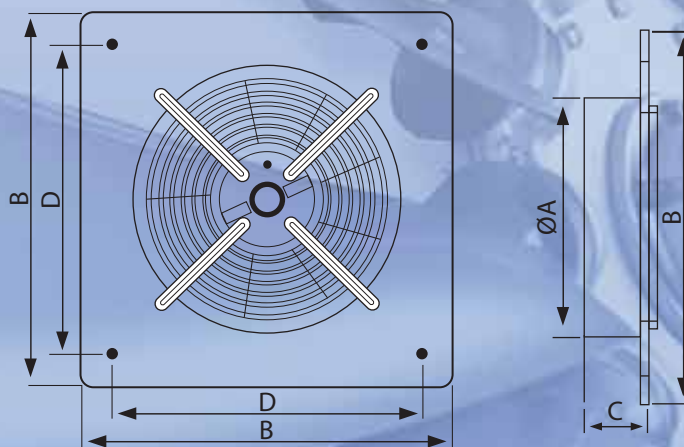

## ACCESSORIES

| MODEL | SPEED CONTROL |
|-------|---------------|
|       | RS-1-400      |

## AWC Series

### Wall Type Axial Fans



#### Fan:

- Motor-rotor air flow direction.
- PL version rotors in fibreglass-reinforced polyamide-6 and AL version rotors in cast aluminium.
- Sheet metal support ring.

#### Motor:

- IE3 efficiency motors for powers equal to or greater than 0.75kW except single-phase, 2-speed and 8-pole.
- Class F motors with ball bearings. IP55 protection, except single-phase models from size 45 to size 56. IP54 protection. 1 or 2 speeds, depending on model.
- Single-phase 230V-50Hz and three-phase 230/400V-50Hz (up to 4kW) and 400/690V-50Hz (powers greater than 4kW).
- Operating temperature: -25°C +50°C.

#### Finish:

- Anticorrosive finish of polyester resin polymerised at 190°C, previously degreased with phosphate-free nanotechnological treatment.

#### On request:

- Motor-rotor air flow direction.
- Rotors 100% reversible.
- Special windings for different voltages.



TECHNICAL SPECIFICATIONS

| MODEL    | MAX.AIR FLOW(m <sup>3</sup> /h) | Watt | SOUND (dBA) | RPM (dk) | PRICE  |
|----------|---------------------------------|------|-------------|----------|--------|
| 25U/4.T  | 1300                            | 0,18 | 68          | 1450     | 385 €  |
| 28U/4.T  | 1650                            | 0,18 | 70          | 1450     | 460 €  |
| 31U/4.T  | 2350                            | 0,18 | 71          | 1450     | 428 €  |
| 35U/4.T  | 3100                            | 0,18 | 72          | 1450     | 471 €  |
| 40U/4.T  | 5000                            | 0,25 | 76          | 1450     | 514 €  |
| 45U/4.T  | 5800                            | 0,37 | 78          | 1450     | 535 €  |
| 50U/4.T  | 7000                            | 0,55 | 79          | 1450     | 589 €  |
| 56U/4.T  | 9000                            | 0,55 | 80          | 1450     | 664 €  |
| 63U/4.T  | 11500                           | 0,75 | 81          | 1450     | 706 €  |
| 63U/4.T1 | 14000                           | 1,50 | 85          | 1450     | 750 €  |
| 63U/4.T2 | 17000                           | 2,20 | 88          | 1450     | 819 €  |
| 63U/4.T3 | 22000                           | 3,00 | 92          | 1450     | 875 €  |
| 25U/2T   | 2150                            | 0,25 | 81          | 2950     | 482 €  |
| 28U/2T   | 3000                            | 0,37 | 83          | 2950     | 514 €  |
| 31U/2T   | 4000                            | 0,55 | 85          | 2950     | 589 €  |
| 35U/2T   | 5500                            | 1,10 | 89          | 2950     | 750 €  |
| 40U/2T   | 8000                            | 1,50 | 92          | 2950     | 875 €  |
| 56U/6T   | 5800                            | 0,18 | 72          | 1000     | 632 €  |
| 63U/6T   | 7400                            | 0,25 | 73          | 1000     | 750 €  |
| 71U/6T   | 13000                           | 0,75 | 80          | 1000     | 995 €  |
| 80U/6T   | 17500                           | 1,10 | 82          | 1000     | 1156 € |
| 90U/6T   | 23000                           | 1,50 | 83          | 1000     | 1391 € |
| 100U/6T  | 30000                           | 2.20 | 85          | 1000     | 1477 € |

AIR FLOW PERFORMANCE DATA

| MODEL    | AIR FLOW DATA / PA / (m <sup>3</sup> /h) |      |       |       |       |       |       |       |       |       |
|----------|------------------------------------------|------|-------|-------|-------|-------|-------|-------|-------|-------|
|          | 0                                        | 25   | 50    | 75    | 100   | 125   | 150   | 175   | 200   | 250   |
| 25U/4.T  | 1300                                     | 1050 | 780   | -     | -     | -     | -     | -     | -     | -     |
| 28U/4.T  | 1650                                     | 1500 | 1230  | -     | -     | -     | -     | -     | -     | -     |
| 31U/4.T  | 2350                                     | 2100 | 1730  | 1400  | -     | -     | -     | -     | -     | -     |
| 35U/4.T  | 3100                                     | 2700 | 2350  | 2000  | -     | -     | -     | -     | -     | -     |
| 40U/4.T  | 5000                                     | 4500 | 4100  | 3500  | 3150  | 2650  | -     | -     | -     | -     |
| 45U/4.T  | -                                        | 5800 | 5350  | 5000  | 4650  | 4100  | 3350  | -     | -     | -     |
| 50U/4.T  | -                                        | -    | 7000  | 6550  | 6150  | 5700  | 5000  | -     | -     | -     |
| 56U/4.T  | -                                        | -    | 9000  | 8600  | 8100  | 7550  | 6800  | 6000  | -     | -     |
| 63U/4.T  | -                                        | -    | 11500 | 11000 | 10400 | 9750  | 9000  | 8100  | 7100  | -     |
| 63U/4.T1 | -                                        | -    | -     | 14000 | 13500 | 13000 | 12500 | 12000 | 11500 | 9500  |
| 63U/4.T2 | -                                        | -    | -     | 17000 | 16500 | 16000 | 15500 | 15000 | 14500 | 13000 |
| 63U/4.T3 | -                                        | -    | -     | 22000 | 20500 | 20000 | 19500 | 18800 | 18000 | 16000 |
| 2950 d/d | 100                                      | 150  | 200   | 250   | 300   | 400   | 500   | 600   |       |       |
| 25U/2T   | 2150                                     | 2000 | 1700  | 1270  | -     | -     | -     | -     | -     | -     |
| 28U/2T   | 3000                                     | 2820 | 2500  | 2250  | 1780  | -     | -     | -     | -     | -     |
| 31U/2T   | -                                        | 4000 | 3600  | 3300  | 3000  | -     | -     | -     | -     | -     |
| 35U/2T   | -                                        | 5500 | 5235  | 5000  | 4750  | 4100  | -     | -     | -     | -     |
| 40U/2T   | -                                        | -    | 8000  | 7600  | 7300  | 6550  | 5710  | 3510  |       |       |
| 1000 d/d | 0                                        | 25   | 50    | 75    | 100   | 125   | 150   | 175   | 200   | 225   |
| 56U/6T   | -                                        | 5800 | 5000  | 4000  | 2000  | -     | -     | -     | -     | -     |
| 63U/6T   | -                                        | 7400 | 6500  | 5400  | 3250  | -     | -     | -     | -     | -     |
| 71U/6T   | -                                        | -    | 13000 | 12150 | 11000 | 9300  | -     | -     | -     | -     |
| 80U/6T   | -                                        | -    | 17500 | 16500 | 15300 | 13800 | 11450 | 8100  | -     | -     |
| 90U/6T   | -                                        | -    | 23000 | 22000 | 20500 | 18800 | 16200 | 13000 | 10350 | -     |
| 100U/6T  | -                                        | -    | 30000 | 28700 | 27000 | 25200 | 23100 | 20500 | 17100 | 13500 |

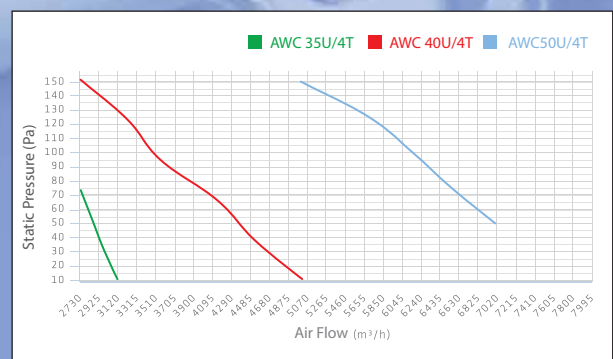
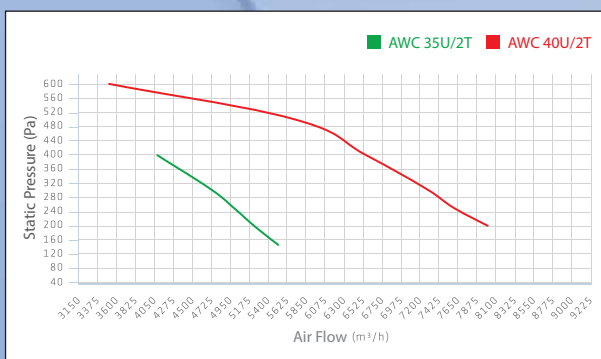
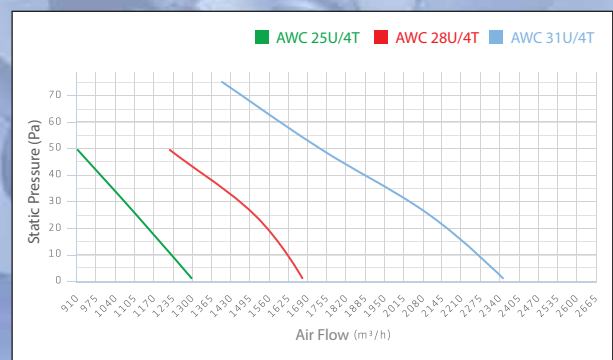
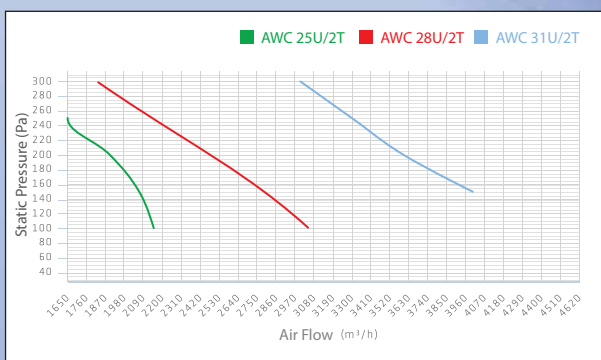

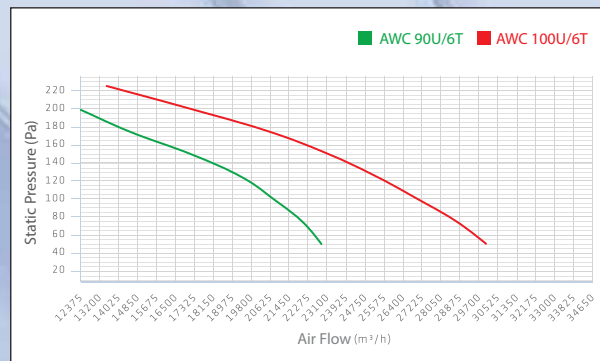
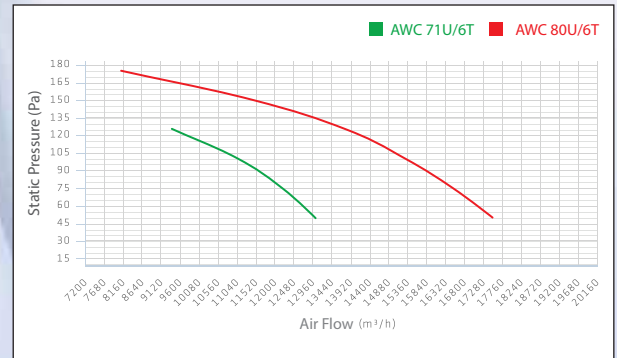
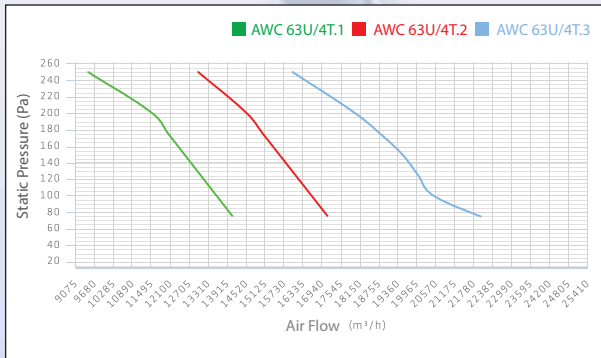
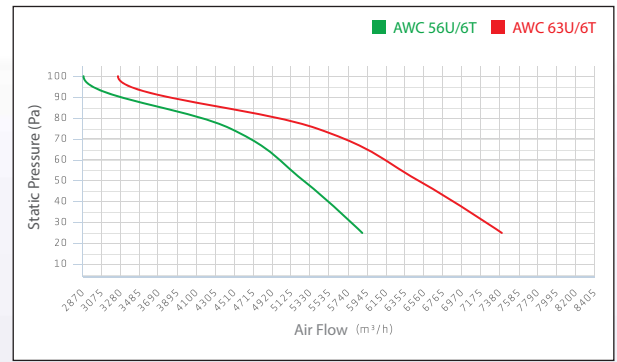
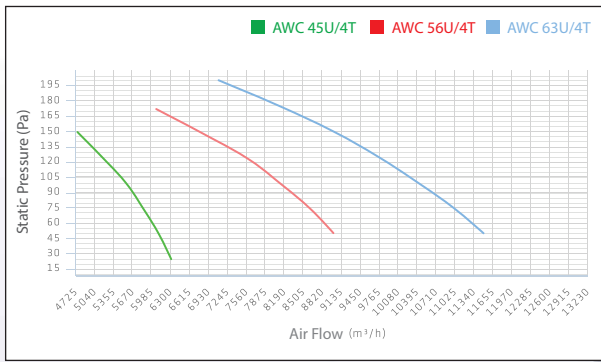

DIMENSIONS

| MODEL    | DIMENSIONS / mm |      |      |         |     |     |
|----------|-----------------|------|------|---------|-----|-----|
|          | ØD              | □A   | □B   | ØF A QD | E   | C   |
| 25U2/4/6 | 250             | 430  | 370  | 330     | 250 | 160 |
| 28U2/4/6 | 280             | 430  | 370  | 360     | 250 | 160 |
| 31U2/4/6 | 315             | 565  | 505  | 395     | 330 | 200 |
| 35U2/4/6 | 355             | 565  | 505  | 435     | 330 | 200 |
| 40U2/4/6 | 400             | 720  | 620  | 480     | 360 | 200 |
| 45U2/4/6 | 450             | 720  | 620  | 530     | 360 | 200 |
| 50U2/4/6 | 500             | 720  | 620  | 590     | 360 | 200 |
| 56U2/4/6 | 560             | 920  | 840  | 650     | 400 | 200 |
| 63U2/4/6 | 630             | 920  | 840  | 720     | 400 | 200 |
| 71U/4/6  | 710             | 920  | 840  | 800     | 450 | 200 |
| 80U/4/6  | 800             | 1170 | 1070 | 905     | 450 | 200 |
| 90U/4/6  | 900             | 1170 | 1070 | 1110    | 500 | 200 |
| 100U/4/6 | 1000            | 1400 | 1400 | 1200    | 500 | 250 |

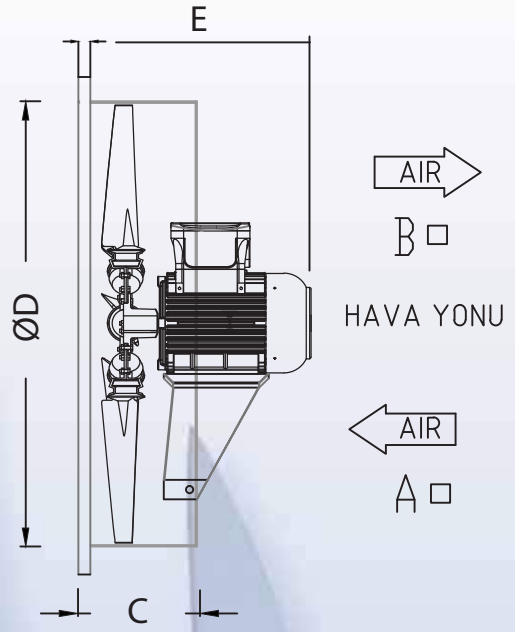
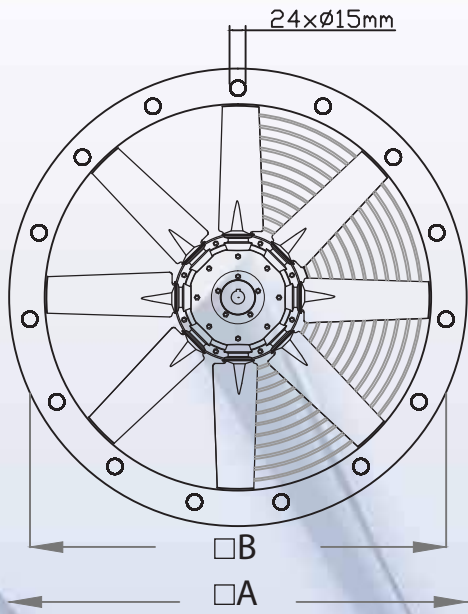

ACCESSORY CONNECTION DIAGRAM

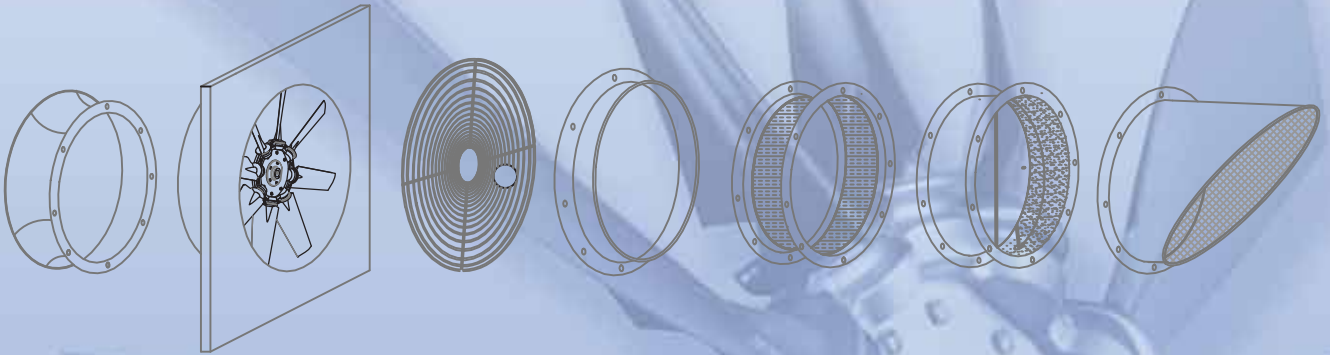

### Description

For the purpose of estimating costs, the steps on the following pages may be bypassed. Allow 5N of thrust per 100m<sup>2</sup> of car park floor area to approximate the number of fans required.

#### Estimating fan quantities

The following steps are sufficient to create an initial impulse ventilation system design. A Computational Fluid Dynamics (CFD) analysis is often required to prove and further refine the design. Fans may need to be re-orientated, or in some cases, added or removed. An impulse ventilation system can be tailored to suit virtually any car park. Before considering fan locations, the system layout will need to be identified. Refer to the previous section for information relating to system layouts and their suitability for particular car parks.

#### Step 1 - Assessing Car Park Geometry

First identify the supply and exhaust points in the car park. A system that complements the natural air path and is able to circulate or move air effectively within the car park should be chosen. Certain layout features may assist the effectiveness of a particular layout as shown below:

##### (a) 'Natural air path'



Figure 6(a). Preferred natural air path

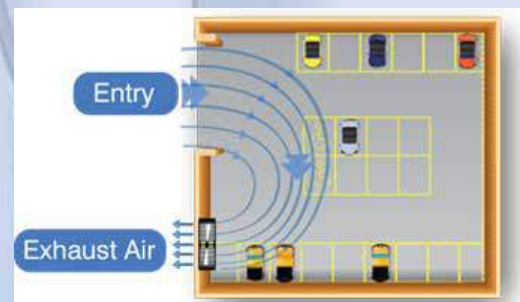

Figure 6(b). Natural air path to be avoided

- For 'Linear Flow Systems', supply and exhaust points should be spaced across the length of a car park.
- 'Circular Mixing Systems' are more tolerant of closely placed supply and exhaust points, but it is advisable to have a good amount of separation.
- Supply air points should include access ramps to outside.
- The impulse ventilation system layout should complement the natural air path from supply to exhaust points.

##### (b) Ceiling features

To make the system more effective, position JetVent Fans in-line with supporting ceiling beams as illustrated in Figure 7(a). If this is not possible, the system becomes less effective and more fans may be needed.

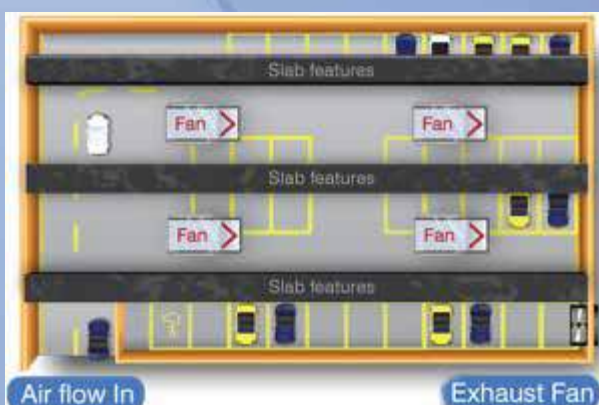

Figure 7(a). Fan's air movement parallel to beams is most effective



Figure 7(b). Fan's air movement perpendicular to beams is less effective

**AQC Series**  
Wall Type Axial Fans



Wall-mounted axial fans with reinforced plastic rotor made of fibreglass.

**Fan:**

- Sheet metal support base.
- Fibreglass reinforced polyamide-6 rotors.
- Anti-contact protective grille pursuant to standard UNE-EN ISO 12499.
- Motor-rotor air flow direction.

**Motor:**

- IE3 efficiency motors for powers equal to or greater than 0.75kW except single-phase. 2-speed and 8-pole.
- Class F motors with ball bearings. IP55 protection. except single-phase models from size 45 to size 63. IP54 protection. 1 or 2 speeds. depending on model.
- Single-phase 230V-50Hz and three-phase 230/400V-50Hz (up to 4kW) and 400/690V-50Hz (powers greater than 4kW).
- Operating temperature: -25°C +60°C

**Finish:**

- Anticorrosive finish of polyester resin polymerised at 190°C. previously degreased with phosphate-free nanotechnological treatment.

**On request:**

- Motor, rotor and grille unit (version F).
- Rotor motor unit. version G.
- Motor-rotor air flow direction.
- Special windings for different voltages.

TECHNICAL SPECIFICATIONS

| MODEL    | MAX.AIR FLOW(m <sup>3</sup> /h) | Watt | SOUND (dBA) | RPM (dk) | PRICE  |
|----------|---------------------------------|------|-------------|----------|--------|
| 25U/4.T  | 1300                            | 0,18 | 68          | 1450     | 385 €  |
| 28U/4.T  | 1650                            | 0,18 | 70          | 1450     | 460 €  |
| 31U/4.T  | 2350                            | 0,18 | 71          | 1450     | 428 €  |
| 35U/4.T  | 3100                            | 0,18 | 72          | 1450     | 471 €  |
| 40U/4.T  | 5000                            | 0,25 | 76          | 1450     | 514 €  |
| 45U/4.T  | 5800                            | 0,37 | 78          | 1450     | 535 €  |
| 50U/4.T  | 7000                            | 0,55 | 79          | 1450     | 589 €  |
| 56U/4.T  | 9000                            | 0,55 | 80          | 1450     | 664 €  |
| 63U/4.T  | 11500                           | 0,75 | 81          | 1450     | 706 €  |
| 63U/4.T1 | 14000                           | 1,50 | 85          | 1450     | 750 €  |
| 63U/4.T2 | 17000                           | 2,20 | 88          | 1450     | 819 €  |
| 63U/4.T3 | 22000                           | 3,00 | 92          | 1450     | 875 €  |
| 25U/2T   | 2150                            | 0,25 | 81          | 2950     | 482 €  |
| 28U/2T   | 3000                            | 0,37 | 83          | 2950     | 514 €  |
| 31U/2T   | 4000                            | 0,55 | 85          | 2950     | 589 €  |
| 35U/2T   | 5500                            | 1,10 | 89          | 2950     | 750 €  |
| 40U/2T   | 8000                            | 1,50 | 92          | 2950     | 875 €  |
| 56U/6T   | 5800                            | 0,18 | 72          | 1000     | 632 €  |
| 63U/6T   | 7400                            | 0,25 | 73          | 1000     | 750 €  |
| 71U/6T   | 13000                           | 0,75 | 80          | 1000     | 995 €  |
| 80U/6T   | 17500                           | 1,10 | 82          | 1000     | 1156 € |
| 90U/6T   | 23000                           | 1,50 | 83          | 1000     | 1391 € |
| 100U/6T  | 30000                           | 2.20 | 85          | 1000     | 1477 € |

AIR FLOW PERFORMANCE DATA

| MODEL    | AIR FLOW DATA / PA / (m <sup>3</sup> /h) |      |       |       |       |       |       |       |       |       |
|----------|------------------------------------------|------|-------|-------|-------|-------|-------|-------|-------|-------|
|          | 0                                        | 25   | 50    | 75    | 100   | 125   | 150   | 175   | 200   | 250   |
| 25U/4.T  | 1300                                     | 1050 | 780   | -     | -     | -     | -     | -     | -     | -     |
| 28U/4.T  | 1650                                     | 1500 | 1230  | -     | -     | -     | -     | -     | -     | -     |
| 31U/4.T  | 2350                                     | 2100 | 1730  | 1400  | -     | -     | -     | -     | -     | -     |
| 35U/4.T  | 3100                                     | 2700 | 2350  | 2000  | -     | -     | -     | -     | -     | -     |
| 40U/4.T  | 5000                                     | 4500 | 4100  | 3500  | 3150  | 2650  | -     | -     | -     | -     |
| 45U/4.T  | -                                        | 5800 | 5350  | 5000  | 4650  | 4100  | 3350  | -     | -     | -     |
| 50U/4.T  | -                                        | -    | 7000  | 6550  | 6150  | 5700  | 5000  | -     | -     | -     |
| 56U/4.T  | -                                        | -    | 9000  | 8600  | 8100  | 7550  | 6800  | 6000  | -     | -     |
| 63U/4.T  | -                                        | -    | 11500 | 11000 | 10400 | 9750  | 9000  | 8100  | 7100  | -     |
| 63U/4.T1 | -                                        | -    | -     | 14000 | 13500 | 13000 | 12500 | 12000 | 11500 | 9500  |
| 63U/4.T2 | -                                        | -    | -     | 17000 | 16500 | 16000 | 15500 | 15000 | 14500 | 13000 |
| 63U/4.T3 | -                                        | -    | -     | 22000 | 20500 | 20000 | 19500 | 18800 | 18000 | 16000 |
| 2950 d/d | 100                                      | 150  | 200   | 250   | 300   | 400   | 500   | 600   |       |       |
| 25U/2T   | 2150                                     | 2000 | 1700  | 1270  | -     | -     | -     | -     | -     | -     |
| 28U/2T   | 3000                                     | 2820 | 2500  | 2250  | 1780  | -     | -     | -     | -     | -     |
| 31U/2T   | -                                        | 4000 | 3600  | 3300  | 3000  | -     | -     | -     | -     | -     |
| 35U/2T   | -                                        | 5500 | 5235  | 5000  | 4750  | 4100  | -     | -     | -     | -     |
| 40U/2T   | -                                        | -    | 8000  | 7600  | 7300  | 6550  | 5710  | 3510  |       |       |
| 1000 d/d | 0                                        | 25   | 50    | 75    | 100   | 125   | 150   | 175   | 200   | 225   |
| 56U/6T   | -                                        | 5800 | 5000  | 4000  | 2000  | -     | -     | -     | -     | -     |
| 63U/6T   | -                                        | 7400 | 6500  | 5400  | 3250  | -     | -     | -     | -     | -     |
| 71U/6T   | -                                        | -    | 13000 | 12150 | 11000 | 9300  | -     | -     | -     | -     |
| 80U/6T   | -                                        | -    | 17500 | 16500 | 15300 | 13800 | 11450 | 8100  | -     | -     |
| 90U/6T   | -                                        | -    | 23000 | 22000 | 20500 | 18800 | 16200 | 13000 | 10350 | -     |
| 100U/6T  | -                                        | -    | 30000 | 28700 | 27000 | 25200 | 23100 | 20500 | 17100 | 13500 |

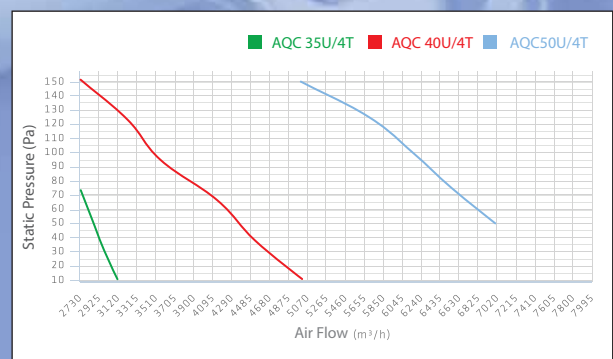
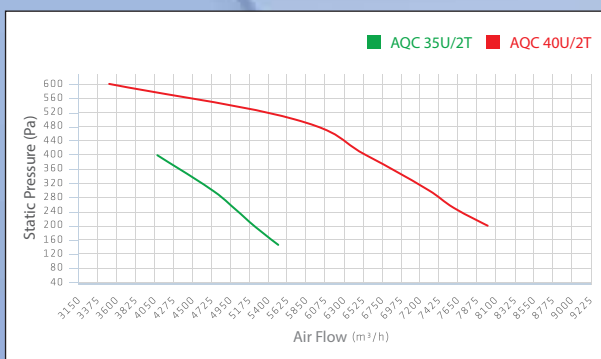
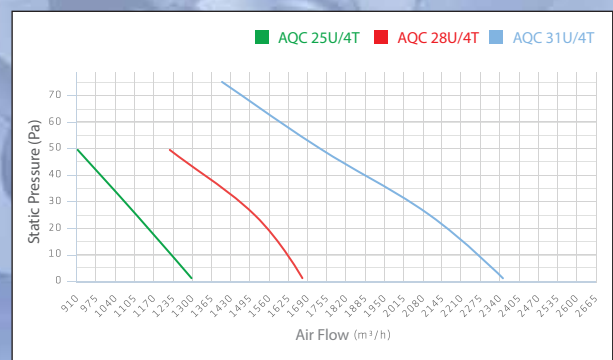
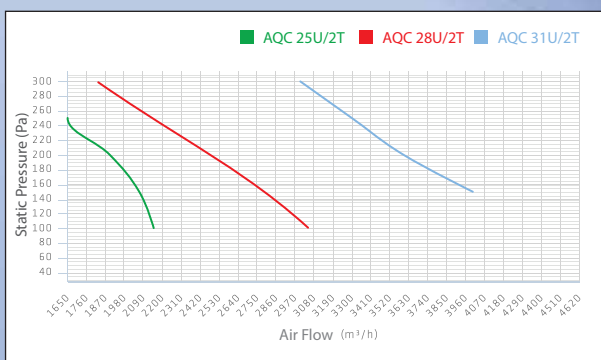



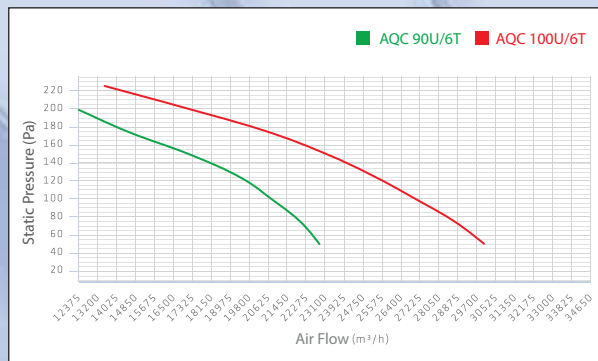
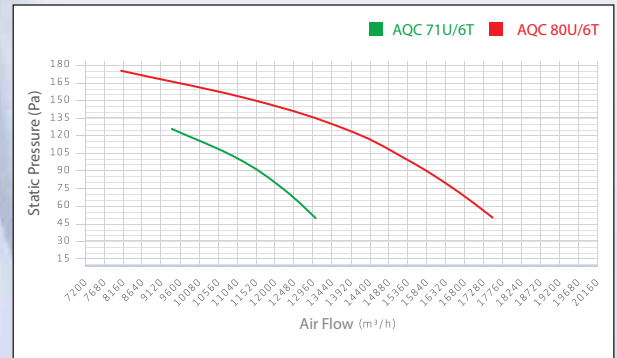
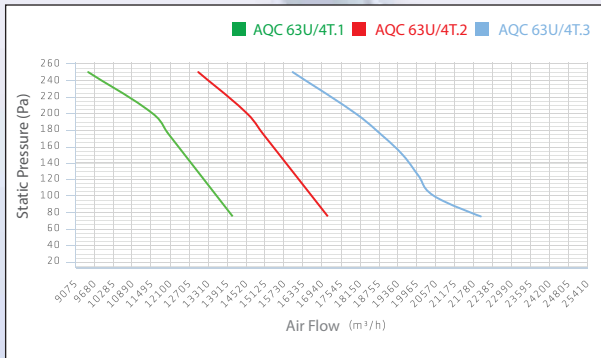
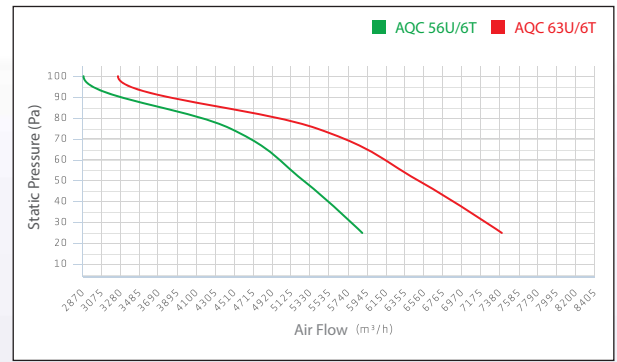
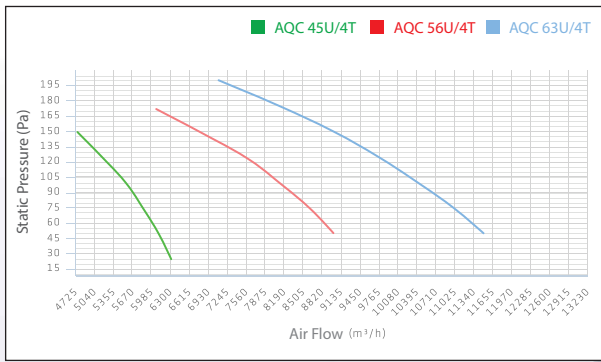

DIMENSIONS

| MODEL    | DIMENSIONS / mm |      |      |        |     |     |
|----------|-----------------|------|------|--------|-----|-----|
|          | ØD              | □A   | □B   | ØF AQC | E   | C   |
| 25U2/4/6 | 250             | 430  | 370  | 330    | 250 | 160 |
| 28U2/4/6 | 280             | 430  | 370  | 360    | 250 | 160 |
| 31U2/4/6 | 315             | 565  | 505  | 395    | 330 | 200 |
| 35U2/4/6 | 355             | 565  | 505  | 435    | 330 | 200 |
| 40U2/4/6 | 400             | 720  | 620  | 480    | 360 | 200 |
| 45U2/4/6 | 450             | 720  | 620  | 530    | 360 | 200 |
| 50U2/4/6 | 500             | 720  | 620  | 590    | 360 | 200 |
| 56U2/4/6 | 560             | 920  | 840  | 650    | 400 | 200 |
| 63U2/4/6 | 630             | 920  | 840  | 720    | 400 | 200 |
| 71U4/6   | 710             | 920  | 840  | 800    | 450 | 200 |
| 80U4/6   | 800             | 1170 | 1070 | 905    | 450 | 200 |
| 90U4/6   | 900             | 1170 | 1070 | 1110   | 500 | 200 |
| 100U4/6  | 1000            | 1400 | 1400 | 1200   | 500 | 250 |

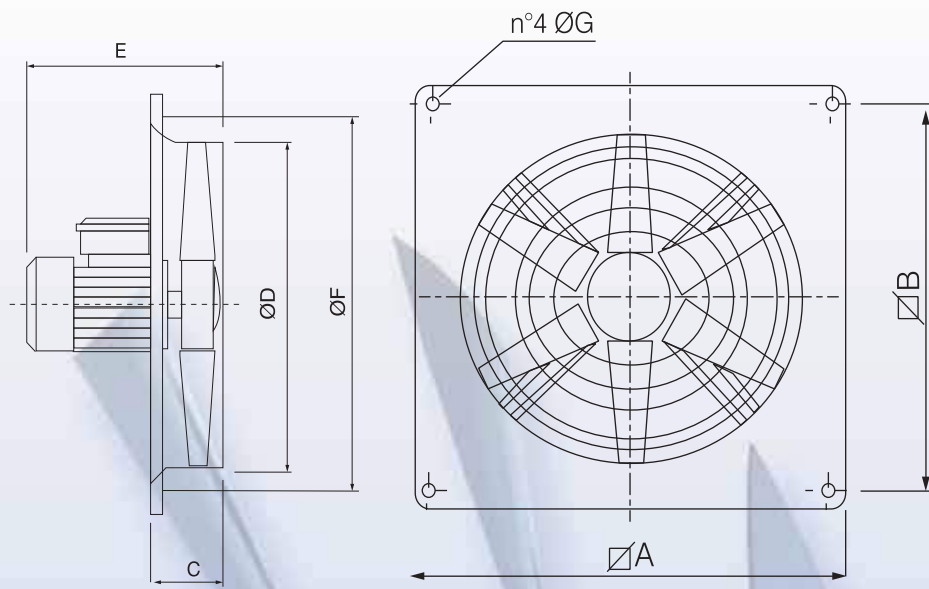

ACCESSORY CONNECTION DIAGRAM

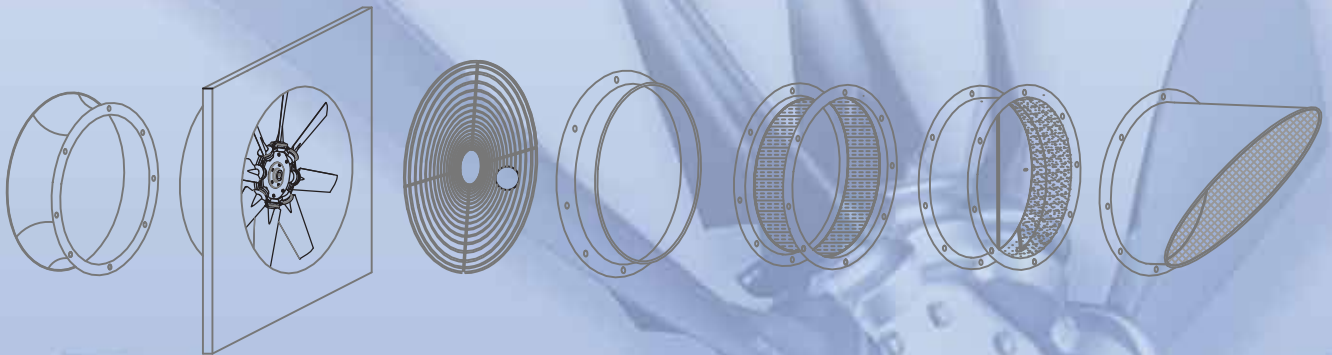

### (c) Vertical clearance

Sufficient vertical clearance ensures maximum flexibility in system design. JetVent Fans may be recessed between ceiling beams to minimise the height of the system.

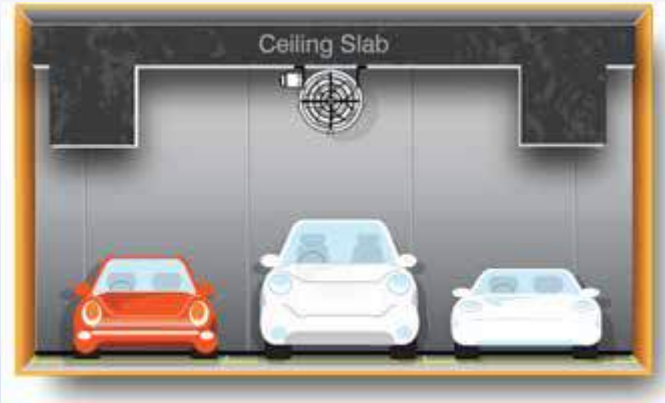

Figure 8(a). Sufficient clearance



Figure 8(b). Insufficient clearance

### (d) Obstructions

If there is no option and the JetVent Fans must blow across ceiling beams, they have to be positioned a sufficient distance away from the obstruction as illustrated in Figure 9(b). A horizontal distance eight times (8x) the height of the obstruction is generally sufficient. Nozzles on the JetVent units are specially designed and angled downwards for this purpose.

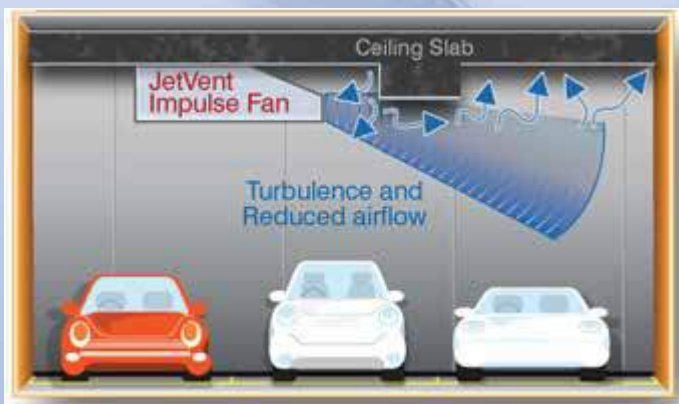

Figure 9(a). Obstruction too close



Figure 9(b). Obstruction out of the way

### (e) Clashes with other services

Place mechanical service components, such as sprinklers, signs and pipework out of the JetVent's discharge pattern area. Examples of these clashes are shown below.

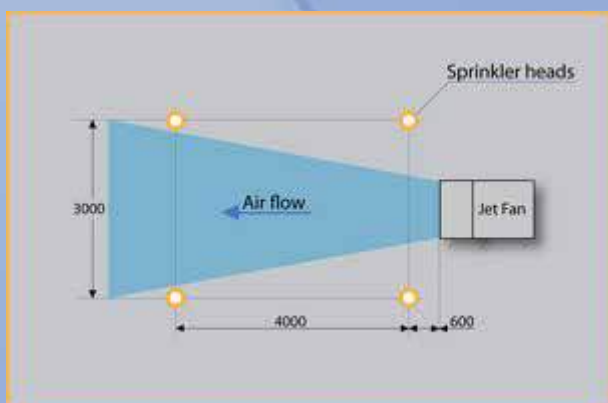

Figure 10(a). An example of how to avoid clashes with pipe-work



Figure 10(b). Jet fan layout in relation to sprinkler heads

## TURBO SERIES

### Inline Type Mixed-Flow Fans



Air flow:  
up to 1750m<sup>3</sup>/h  
486l/s



Power:  
from 23 W



Noise level:  
from 27 dBA



#### Use

Supply and extract ventilation systems installed in various premises. Mounting in kitchens, bathrooms and other humid premises. Ventilation air ducts requiring high pressure, powerful air flow and low noise level. Compatible with Ø 100 up to 315 mm round air ducts.

#### Design

Casing made of low-flammable polypropylene. Ventilation unit with terminal box. Can be turned to any position. Special design of the casing permits easy dismantling of the impeller and motor block for fan servicing without dismantling the air duct.

#### Motor

Double-speed single-phase motor on ball bearings. Equipped with thermal overload protection.

#### Speed control

The built-in switch (option US) or external switch for multi-speed fans (available upon separate order) are used to select one of two capacity modes. Smooth speed control is possible with a built-in speed controller (option FR) or an external thyristor speed controller (available upon separate order).

#### Mounting

Due to compact design the fan is the ideal solution for mounting in limited spaces, including space behind a false ceiling. The fan can be installed in any section of the ventilation system from intake to the end of the ductworks. Wall or ceiling mounting with a mounting plate. TD: mounting kit for installation of one diameter fans in parallel (for boosting capacity)



TL: mounting kit for installation of one diameter fans in series (for boosting pressure).



#### Technical data

| Parameters                                 | Turbo 100 |          | Turbo 125 |          | Turbo 150 / Turbo 160 |           |
|--------------------------------------------|-----------|----------|-----------|----------|-----------------------|-----------|
|                                            | min       | max      | min       | max      | min                   | max       |
| Speed                                      |           |          |           |          |                       |           |
| Voltage [V / 50-60 Hz]                     | 1 ~ 230   | 1 ~ 230  | 1 ~ 230   | 1 ~ 230  | 1 ~ 230               | 1 ~ 230   |
| Power [W]                                  | 23        | 25       | 25        | 29       | 42                    | 50        |
| Current [A]                                | 0.10      | 0.11     | 0.11      | 0.13     | 0.19                  | 0.22      |
| Maximum air flow [m <sup>3</sup> /h (l/s)] | 170 (47)  | 220 (61) | 230 (64)  | 345 (96) | 430 (119)             | 560 (156) |
| RPM [min <sup>-1</sup> ]                   | 1980      | 2545     | 1535      | 2265     | 1940                  | 2620      |
| Sound pressure level at 3 m [dBA]          | 27        | 32       | 29        | 34       | 32                    | 44        |
| Max. transported air temperature [°C]      | 60        |          | 60        |          | 60                    |           |
| SEC class                                  | C         |          | B         |          | B                     |           |
| Ingress protection rating                  | IPX4      |          | IPX4      |          | IPX4                  |           |
| Motor IP rating                            | IPX4      |          | IPX4      |          | IPX4                  |           |
| ErP                                        | -         |          | -         |          | 2016, 2018            |           |
| Price                                      | 57 €      |          | 60 €      |          | 71 €                  |           |

| Parameters                                 | Turbo 200  |            | Turbo 250  |            | Turbo 315  |            |
|--------------------------------------------|------------|------------|------------|------------|------------|------------|
|                                            | min        | max        | min        | max        | min        | max        |
| Speed                                      |            |            |            |            |            |            |
| Voltage [V / 50-60 Hz]                     | 1 ~ 230    | 1 ~ 230    | 1 ~ 230    | 1 ~ 230    | 1 ~ 230    | 1 ~ 230    |
| Power [W]                                  | 76         | 108        | 125        | 177        | 227        | 315        |
| Current [A]                                | 0.34       | 0.48       | 0.54       | 0.79       | 0.99       | 1.42       |
| Maximum air flow [m <sup>3</sup> /h (l/s)] | 805 (224)  | 1080 (300) | 1070 (297) | 1360 (378) | 1420 (394) | 1750 (486) |
| RPM [min <sup>-1</sup> ]                   | 1915       | 2380       | 1955       | 2440       | 2115       | 2505       |
| Sound pressure level at 3 m [dBA]          | 39         | 45         | 44         | 51         | 41         | 52         |
| Max. transported air temperature [°C]      | 60         |            | 60         |            | 60         |            |
| SEC class                                  | B          |            | -          |            | -          |            |
| Ingress protection rating                  | IPX4       |            | IPX4       |            | IPX4       |            |
| Motor IP rating                            | IPX4       |            | IPX4       |            | IPX4       |            |
| ErP                                        | 2016, 2018 |            | 2016, 2018 |            | 2016, 2018 |            |
| Price                                      | 91 €       |            | 160 €      |            | 210 €      |            |

### TURBO 100

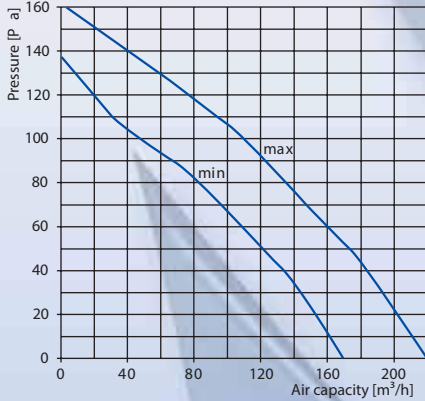

### TURBO 125

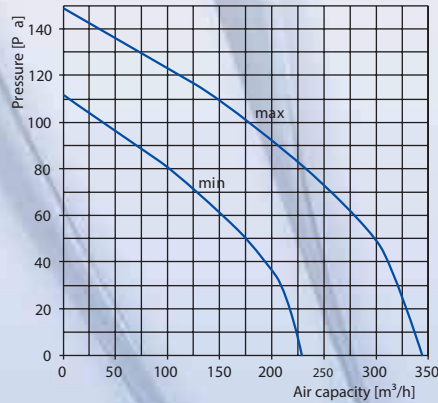

### TURBO 150 / 160

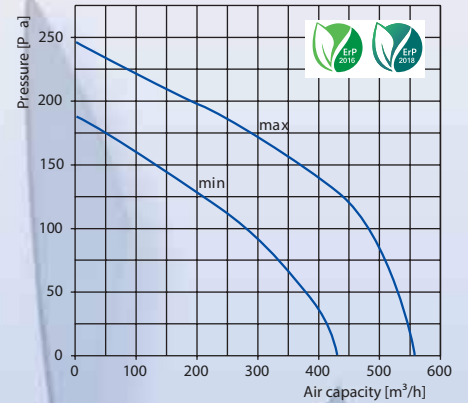

### TURBO 200

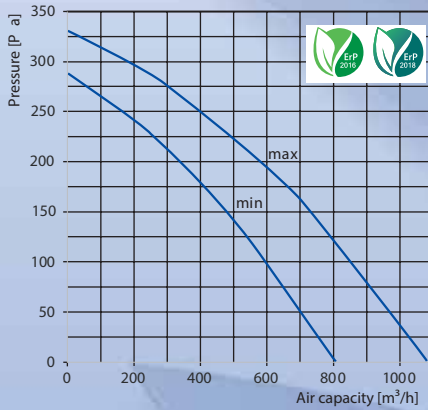

### TURBO 250

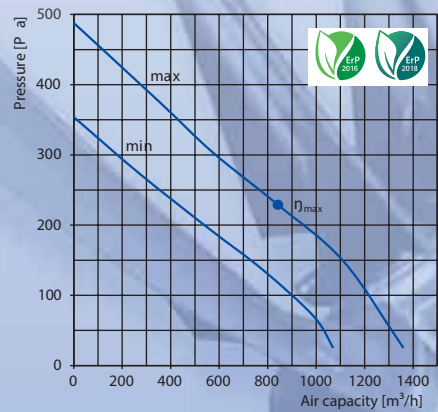

### TURBO 315

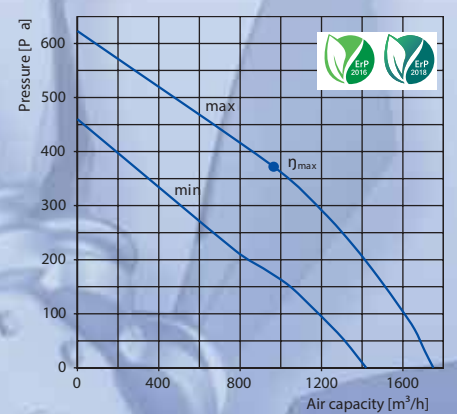

### Overall dimensions [mm]

| Model     | ØD  | ØD1 | B   | H   | L     | Weight [kg] |
|-----------|-----|-----|-----|-----|-------|-------------|
| Turbo 100 | 97  | 164 | 196 | 241 | 303   | 1.68        |
| Turbo 125 | 123 | 164 | 196 | 241 | 258   | 1.79        |
| Turbo 150 | 148 | 187 | 220 | 251 | 289   | 3.18        |
| Turbo 160 | 158 | 187 | 220 | 251 | 289   | 3.23        |
| Turbo 200 | 199 | 209 | 239 | 261 | 295.5 | 3.8         |
| Turbo 250 | 247 | 257 | 287 | 323 | 383   | 7.83        |
| Turbo 315 | 310 | 323 | 362 | 408 | 445   | 11.7        |

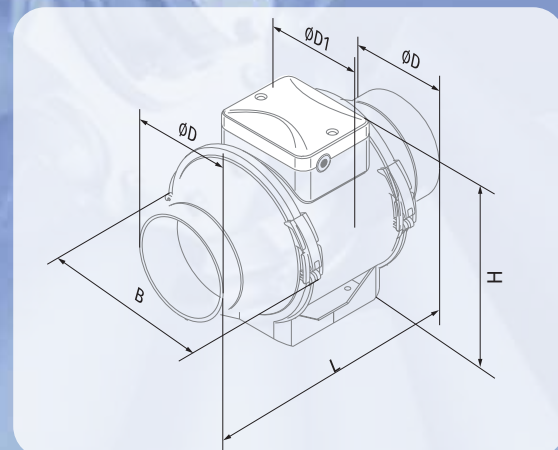

## YKF SERIES

### Inline Type Centrifugal Fan



USE: Supply and exhaust ventilation systems installed in various premises. The best solution both for humid indoor premises and outside areas. Compatible with 100 up to 315 mm round air ducts.

DESIGN: Galvanized steel casing  
Aerodynamically shaped casing.  
External terminal block for power supply.

MOTOR: Single-phase external rotor with a centrifugal impeller with backward curved blades. Equipped with ball bearings for longer service life. Integrated thermal protection with automatic restart. Dynamically balanced turbine. For ventilation of premises with high requirements to noise level low-noise modifications are available.

#### TECHNICAL SPECIFICATIONS

| MODEL   | AIR FLOW (m <sup>3</sup> /h) | Watt | SOUND (dBA) | AMPER | RPM (dk)  | PRICE |
|---------|------------------------------|------|-------------|-------|-----------|-------|
| YKF 100 | 300                          | 33   | 27/36       | 0,21  | 2180/2385 | 63 €  |
| YKF 125 | 450                          | 25   | 27/32       | 0,11  | 1940/2620 | 70 €  |
| YKF 150 | 530                          | 37   | 28/37       | 0,27  | 2180/2385 | 78 €  |
| YKF 160 | 550                          | 30   | 29/34       | 0,13  | 1940/2620 | 79 €  |
| YKF 200 | 1200                         | 60   | 33/44       | 0,27  | 2180/2385 | 92 €  |
| YKF 250 | 1600                         | 108  | 45/52       | 0,48  | 1940/2620 | 102 € |
| YKF 315 | 2000                         | 177  | 47/55       | 0,79  | 1940/2620 | 126 € |

#### AIR FLOW PERFORMANCE DATA

| MODEL   | AIR FLOW PERFORMANCE DATA / PA / (m <sup>3</sup> /h) |      |      |      |      |      |      |     |
|---------|------------------------------------------------------|------|------|------|------|------|------|-----|
|         | 50                                                   | 100  | 150  | 200  | 250  | 300  | 400  | 500 |
| YKF 100 | 250                                                  | 200  | 150  | 120  | 100  | -    | -    | -   |
| YKF 125 | 360                                                  | 280  | 320  | 300  | 170  | -    | -    | -   |
| YKF 150 | 500                                                  | 460  | 380  | 310  | 180  | -    | -    | -   |
| YKF 160 | 510                                                  | 470  | 400  | 320  | 190  | -    | -    | -   |
| YKF 200 | 1000                                                 | 920  | 840  | 700  | 600  | 400  | -    | -   |
| YKF 250 | 1400                                                 | 1310 | 1180 | 1100 | 960  | 900  | 580  | 300 |
| YKF 315 | 1950                                                 | 1900 | 1850 | 1780 | 1700 | 1520 | 1100 | 600 |

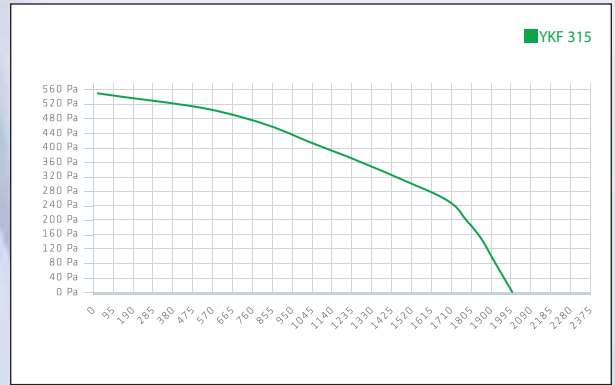
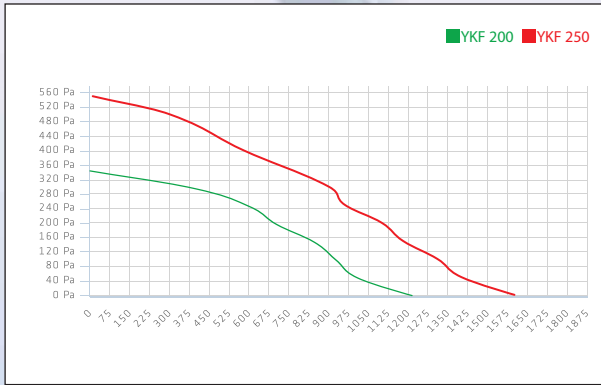
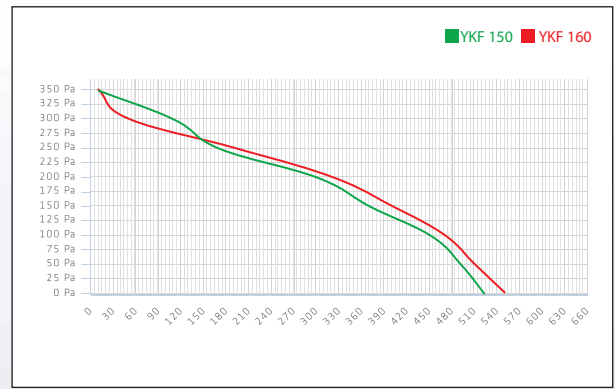
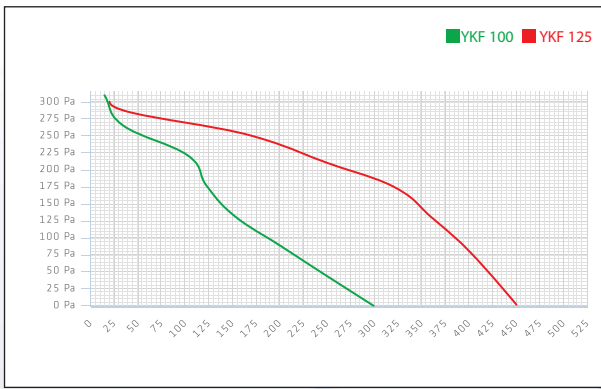

## DIMENSIONS

| MODEL   | DIMENSIONS / mm |     |     |    |     |    |
|---------|-----------------|-----|-----|----|-----|----|
|         | AØ              | B   | C   | D  | E   | F  |
| YKF 100 | 96              | 96  | 243 | 18 | 192 | 22 |
| YKF 125 | 120             | 120 | 243 | 19 | 189 | 18 |
| YKF 150 | 129             | 129 | 270 | 20 | 185 | 27 |
| YKF 160 | 129             | 129 | 270 | 24 | 185 | 35 |
| YKF 200 | 160             | 160 | 344 | 20 | 240 | 25 |
| YKF 250 | 175             | 175 | 344 | 22 | 245 | 25 |
| YKF 315 | 190             | 190 | 401 | 23 | 280 | 34 |

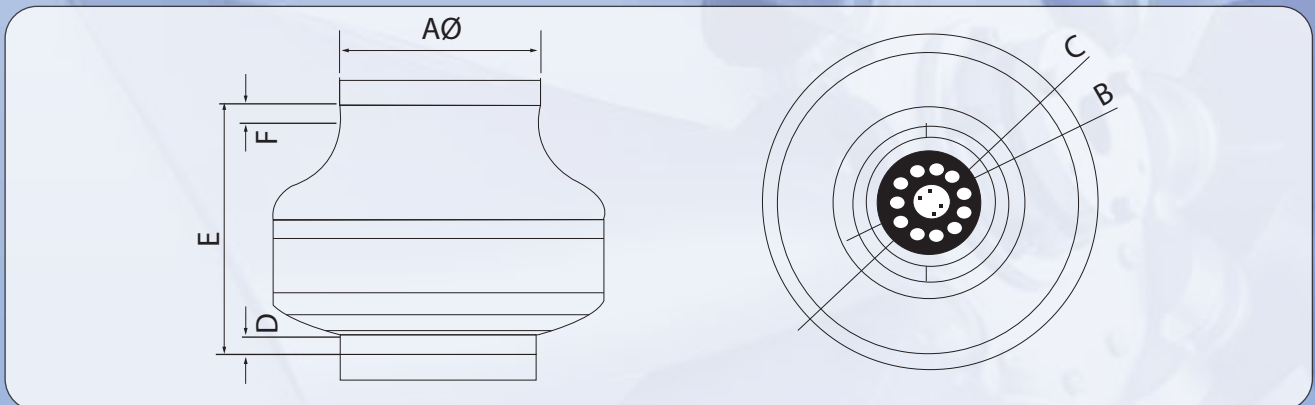

## ACCESSORIES

| MODEL | SPEED CONTROLLER         |
|-------|--------------------------|
|       | TECHNICAL SPECIFICATIONS |

RS-1-400

Electronic, Maximum 1.8 Amper

**AIT Series**  
Inline Type Axial  
Fans



**Fan:**

- Motor-rotor air flow direction.
- Tubular casing in sheet steel with external terminal box.

**Motor:**

- IE3 efficiency motors for powers equal to or greater than 0.75kW except single-phase, 2-speed and 8-pole.
- Class F motors with ball bearings. IP55 protection. except single-phase models from size 45 to size 56. IP54 protection. 1 or 2 speeds. depending on model.
- Single-phase 230V-50Hz and three-phase 230/400V-50Hz (up to 4kW) and 400/690V-50Hz (powers greater than 4kW).
- Operating temperature: -25°C +50°C.

**Finish:**

- Anticorrosive finish of polyester resin polymerised at 190°C. previously degreased with phosphate-free nanotechnological treatment.

**On request:**

- Motor-rotor air flow direction.
- Rotors 100% reversible.
- Special windings for different voltages.



TECHNICAL SPECIFICATIONS

| MODEL     | AIR FLOW(m <sup>3</sup> /h) | Watt  | SOUND (dBA) | RPM  | PRICE  |
|-----------|-----------------------------|-------|-------------|------|--------|
| 35U/4.T   | 3100                        | 0,18  | 72          | 1450 | 402 €  |
| 40U/4.T   | 5000                        | 0,25  | 76          | 1450 | 460 €  |
| 45U/4.T   | 5800                        | 0,37  | 78          | 1450 | 482 €  |
| 50U/4.T   | 7000                        | 0,55  | 79          | 1450 | 567 €  |
| 56U/4.T   | 9000                        | 0,55  | 80          | 1450 | 630 €  |
| 63U/4.T   | 11500                       | 0,75  | 81          | 1450 | 722 €  |
| 63U/4.T1  | 14000                       | 1,50  | 85          | 1450 | 915 €  |
| 63U/4.T2  | 17000                       | 2,20  | 88          | 1450 | 963 €  |
| 63U/4.T3  | 22000                       | 3,00  | 92          | 1450 | 1070 € |
| 35U/2.T   | 5500                        | 1,10  | 89          | 2950 | 572 €  |
| 40U/2.T   | 8000                        | 1,50  | 92          | 2950 | 775 €  |
| 45U/2.T   | 11000                       | 3,00  | 95          | 2950 | 945 €  |
| 50U/2.T   | 14000                       | 4,00  | 96          | 2950 | 1140 € |
| 63U/2.T   | 22700                       | 7,50  | 98          | 2950 | 1430 € |
| 71U/4.T   | 24000                       | 4,00  | 91          | 1450 | 1177 € |
| 80U/4.T   | 28000                       | 5,50  | 92          | 1450 | 1498 € |
| 80U/4.T1  | 33000                       | 7,50  | 96          | 1450 | 1616 € |
| 90U/4.T   | 29000                       | 3,00  | 89          | 1450 | 1327 € |
| 90U/4.T1  | 40000                       | 7,50  | 96          | 1450 | 1712 € |
| 100U/4.T  | 43000                       | 7,50  | 93          | 1450 | 1969 € |
| 100U/4.T1 | 50000                       | 11,00 | 97          | 1450 | 2194 € |
| 125U/4.T  | 61000                       | 15,00 | 95          | 1450 | 2675 € |
| 125U/4.T1 | 88000                       | 30,00 | 101         | 1450 | 3585 € |

AIR FLOW PERFORMANCE DATA

| MODEL    | AIR FLOW PERFORMANCE DATA / PA / (m <sup>3</sup> /h) |      |       |       |       |       |       |       |       |       |
|----------|------------------------------------------------------|------|-------|-------|-------|-------|-------|-------|-------|-------|
|          | 0                                                    | 25   | 50    | 75    | 100   | 125   | 150   | 175   | 200   | 250   |
| 35U/4.T  | 3100                                                 | 2700 | 2350  | 2000  | -     | -     | -     | -     | -     | -     |
| 40U/4.T  | 5000                                                 | 4500 | 4100  | 3500  | 3150  | 2650  | -     | -     | -     | -     |
| 45U/4.T  | -                                                    | 5800 | 5350  | 5000  | 4650  | 4100  | 3350  | -     | -     | -     |
| 50U/4.T  | -                                                    | -    | 7000  | 6550  | 6150  | 5700  | 5000  | -     | -     | -     |
| 63U/4.T  | -                                                    | -    | 11500 | 11000 | 10400 | 9750  | 9000  | 8100  | 7100  | -     |
| 63U/4.T1 | -                                                    | -    | -     | 14000 | 13500 | 13000 | 12500 | 12000 | 11500 | 9500  |
| 63U/4.T2 | -                                                    | -    | -     | 17000 | 16500 | 16000 | 15500 | 15000 | 14500 | 13000 |
| 63U/4.T3 | -                                                    | -    | -     | 22000 | 20500 | 20000 | 19500 | 18800 | 18000 | 16000 |

AIR FLOW PERFORMANCE DATA

| 2800 d/d  | AIR FLOW PERFORMANCE DATA / PA / (m <sup>3</sup> /h) |       |       |       |       |       |       |       |       |       |
|-----------|------------------------------------------------------|-------|-------|-------|-------|-------|-------|-------|-------|-------|
|           | 100                                                  | 150   | 200   | 259   | 300   | 400   | 500   | 600   | 700   | 800   |
| 35U/2.T   | -                                                    | 5500  | 5235  | 5000  | 4750  | 4100  | -     | -     | -     | -     |
| 40U/2.T   | -                                                    | -     | 8000  | 7600  | 7300  | 6550  | 5710  | 3510  | -     | -     |
| 45U/2.T   | -                                                    | -     | -     | 11000 | 10400 | 9700  | 8750  | 7300  | -     | -     |
| 50U/2.T   | -                                                    | -     | -     | 14000 | 13600 | 13000 | 11900 | 10550 | 8900  | -     |
| 63U/2.T   | -                                                    | -     | -     | -     | 22700 | 21600 | 20350 | 18900 | 17200 | 15400 |
| 71U/4.T   | -                                                    | -     | 24000 | 19000 | 16000 | -     | -     | -     | -     | -     |
| 80U/4.T   | 28000                                                | 28000 | 26500 | 25000 | 20000 | 13000 | -     | -     | -     | -     |
| 80U/4.T1  | -                                                    | -     | 33000 | 28000 | 25000 | 20000 | -     | -     | -     | -     |
| 90U/4.T   | 29000                                                | 29000 | 26000 | 23500 | 20000 | 16000 | -     | -     | -     | -     |
| 90U/4.T1  | -                                                    | -     | 40000 | 37000 | 34000 | 27500 | -     | -     | -     | -     |
| 100U/4.T  | 43000                                                | 43000 | 41000 | 39000 | 37500 | 32000 | 25000 | 20000 | -     | -     |
| 100U/4.T1 | -                                                    | -     | 50000 | 48000 | 46500 | 42000 | 35600 | 25000 | -     | -     |
| 125U/4.T  | 61000                                                | 61000 | 60000 | 58000 | 56500 | 55000 | 52000 | 50000 | 45000 | 40000 |
| 125U/4.T1 | -                                                    | -     | -     | 88000 | 85000 | 83000 | 79000 | 76000 | 71000 | 66000 |

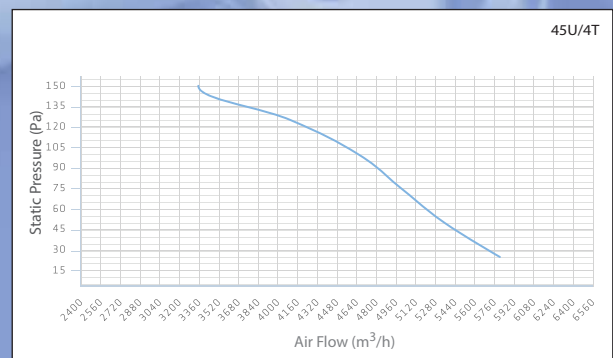
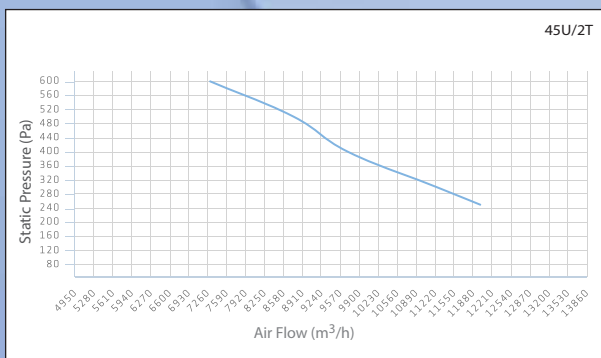
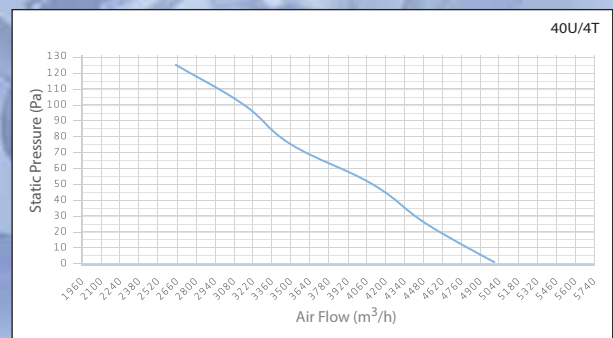
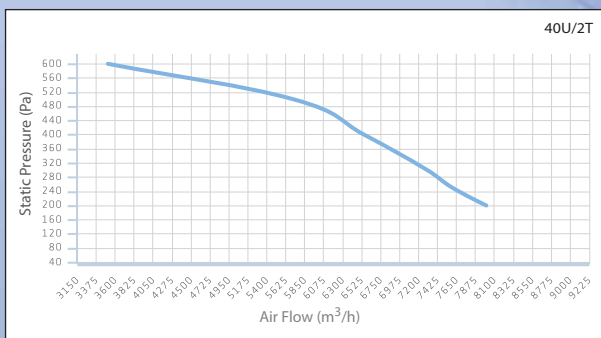
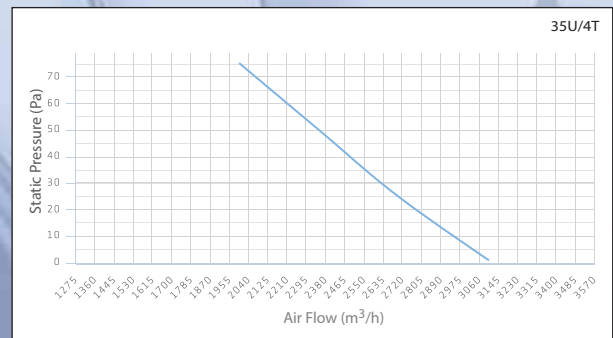
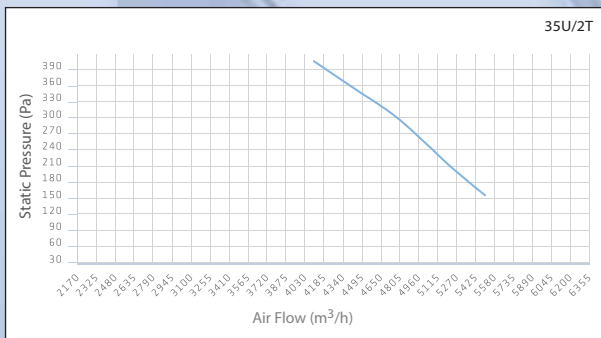

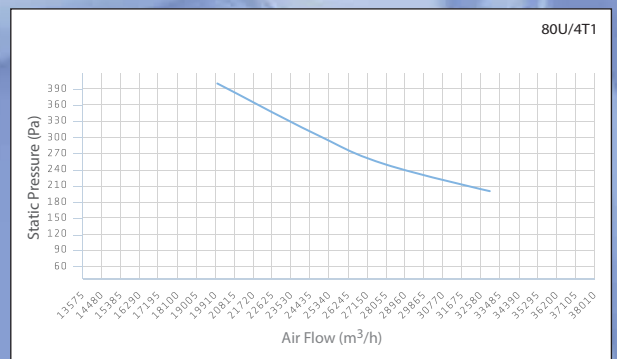
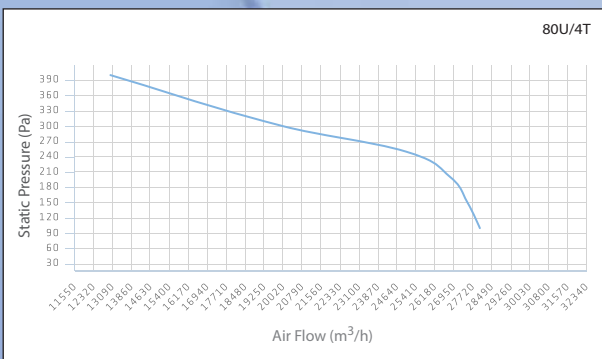
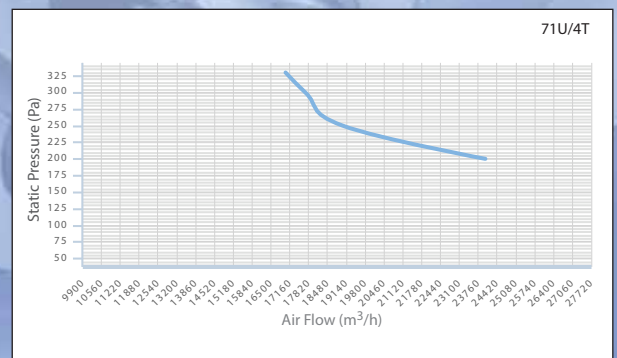
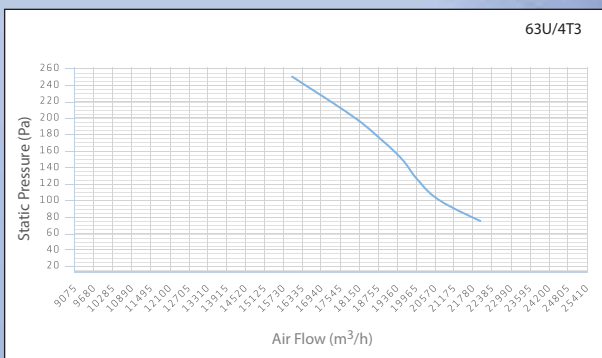
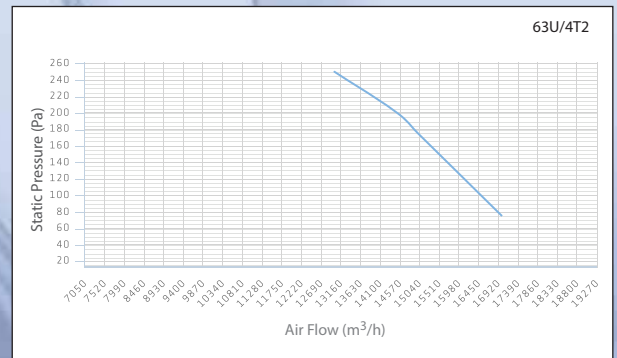
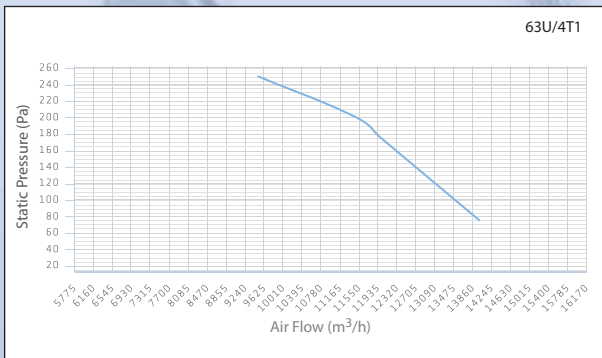
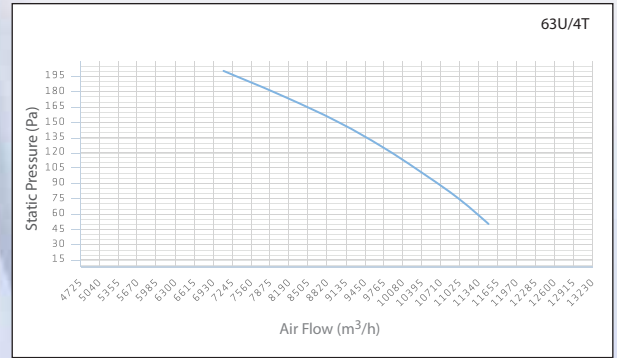
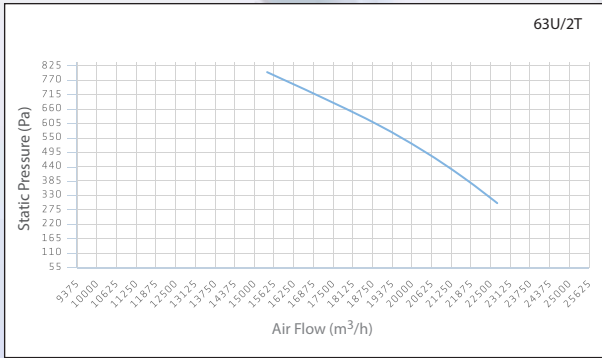
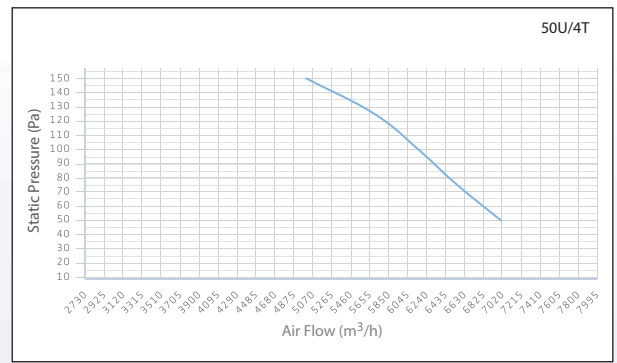
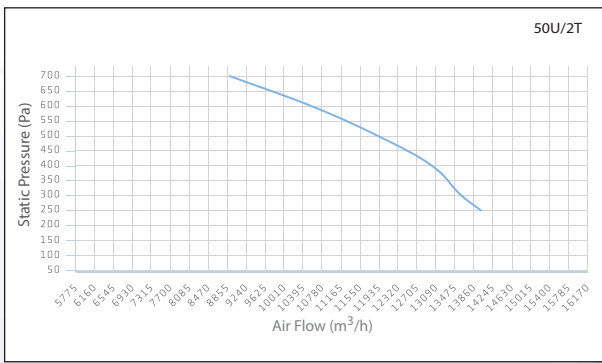

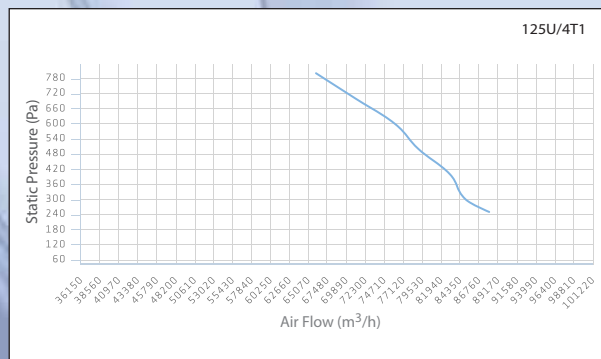
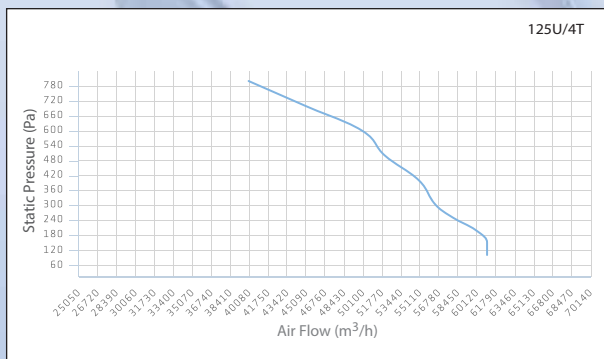
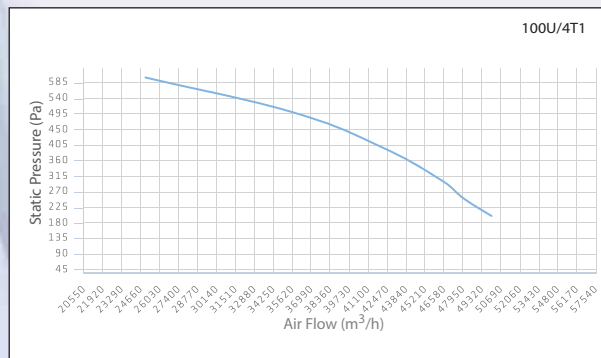
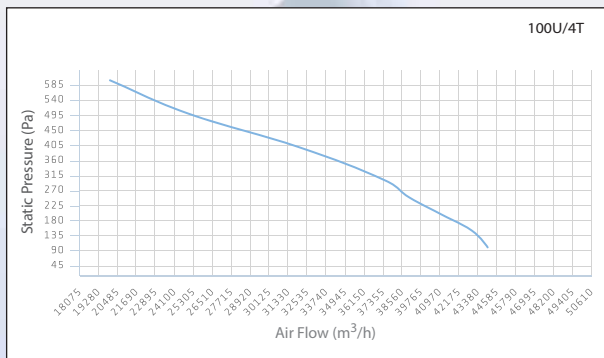
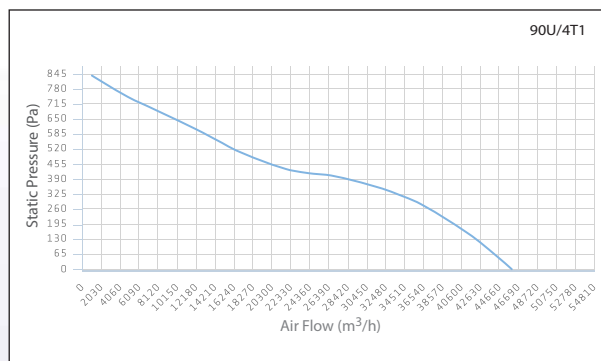
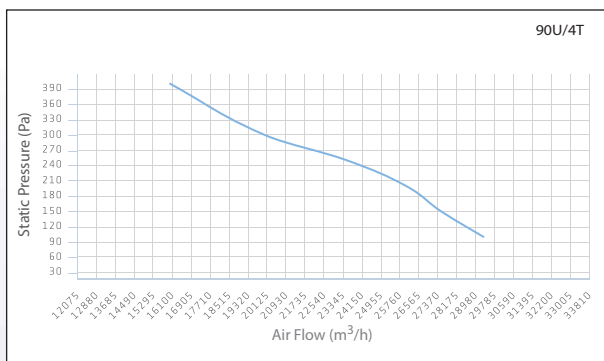

## DIMENSIONS

| MODEL    | DIMENSIONS / mm |      |      |         |     |   |     |
|----------|-----------------|------|------|---------|-----|---|-----|
|          | ØDi             | ØTK  | ØDA  | ZxØ     | L   | S | hf  |
| AIT 25U  | 252             | 295  | 332  | 8 x 10  | 500 | 2 | 176 |
| AIT 28U  | 283             | 322  | 363  | 8 x 10  | 500 | 2 | 192 |
| AIT 31U  | 315             | 356  | 395  | 8 x 10  | 500 | 2 | 208 |
| AIT 35U  | 355             | 395  | 435  | 8 x 10  | 500 | 2 | 228 |
| AIT 40U  | 400             | 450  | 480  | 8 x 12  | 500 | 2 | 270 |
| AIT 45U  | 450             | 500  | 530  | 8 x 12  | 500 | 3 | 295 |
| AIT 50U  | 500             | 560  | 590  | 12 x 12 | 500 | 3 | 320 |
| AIT 63U  | 630             | 690  | 730  | 14 x 12 | 500 | 3 | 385 |
| AIT 71U  | 710             | 770  | 810  | 16 x 14 | 500 | 3 | 425 |
| AIT 80U  | 800             | 860  | 900  | 16 x 14 | 500 | 3 | 470 |
| AIT 90U  | 900             | 970  | 1000 | 16 x 15 | 500 | 4 | 550 |
| AIT 100U | 1000            | 1070 | 1100 | 16 x 15 | 500 | 4 | 600 |
| AIT 112U | 1120            | 1190 | 1220 | 24 x 15 | 750 | 4 | 760 |
| AIT 125U | 1250            | 1320 | 1370 | 24 x 15 | 750 | 6 | 725 |

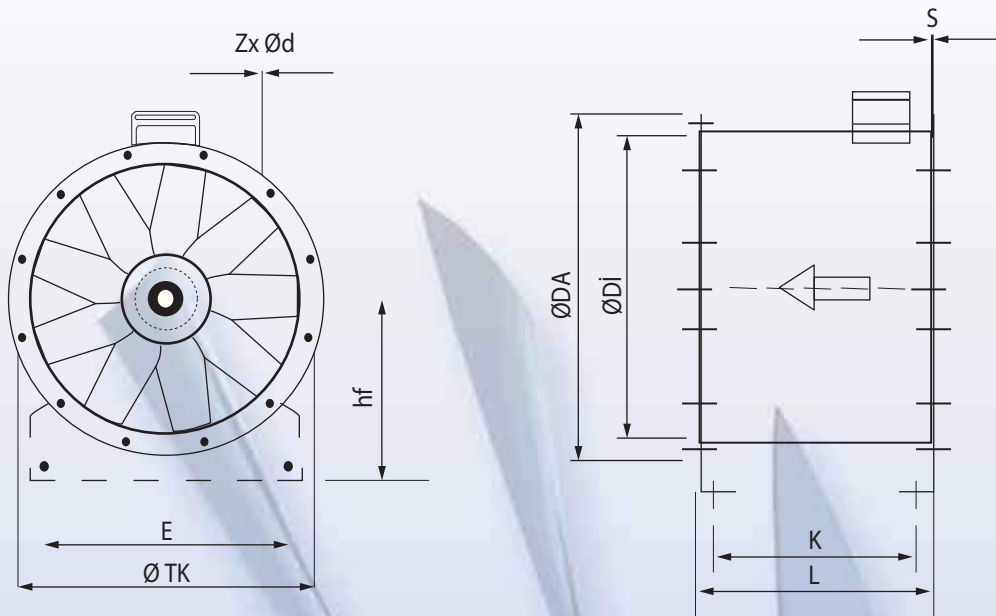

ACCESSORIES CONNECTION DIAGRAMS

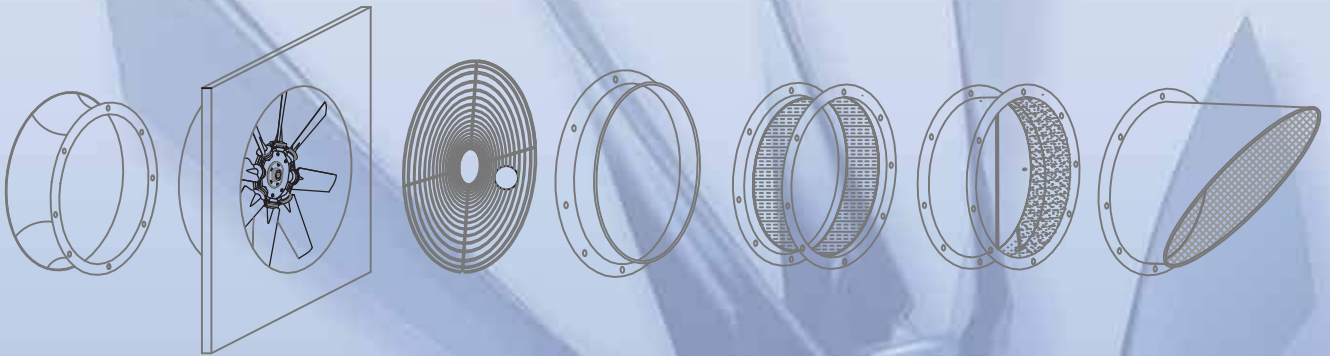

## AITB Series

Bifurcated Axial Fans  
With External Motors



190 °C

### FAN

- Tubular sheet steel casing with rotating cover.
- Cast aluminium rotors.
- Sealed transmission unit (IP66) with double retention system.
- Motor - Rotor air flow direction.
- Operating temperature -25°C + 150°C

### MOTOR

- IE3 efficiency motors for powers equal to or greater than 0,75 KW expect single-phase. 2-speed and 8-pole.
- Class F motors with ball bearings and IP55 protection.
- Single-phase 230V-50Hz and three-phase 230/400V-50Hz (up to 3Kw) and 400/690V-50Hz (powers greater than 3KW)

### FINISH

- Anticorrosive finish of polyester resin polymerised at 190°C. previously degreased with phosphate-free nanotechnological treatment.

### ON REQUEST

- Motor-rotor air flow direction.
- Rotors 100% reversible.
- Special windings for different voltages

## TECHNICAL SPECIFICATIONS

| MODEL   | MAX. AIR FLOW (m <sup>3</sup> /h) | WATT | SOUND (dBA) | RPM (dk) | PRICE  |
|---------|-----------------------------------|------|-------------|----------|--------|
| 71U/4.T | 20000                             | 3,00 | 84          | 1450     | 1766 € |
| 80U/4.T | 26000                             | 4,00 | 86          | 1450     | 2086 € |
| 90U/4.T | 33000                             | 5,50 | 90          | 1450     | 2568 € |

## AIR FLOW PERFORMANCE DATA

| MODEL        | AIR FLOW PERFORMANCE DATA / PA / (m <sup>3</sup> /h) |       |       |       |       |       |       |
|--------------|------------------------------------------------------|-------|-------|-------|-------|-------|-------|
|              | 125                                                  | 150   | 175   | 200   | 250   | 300   | 350   |
| AITB 71U/4.T | 20000                                                | 19500 | 19000 | 18500 | 16000 | 12000 | 10000 |
| AITB 80U/4.T | -                                                    | 26000 | 25000 | 23500 | 22500 | 18000 | 16000 |
| AITB 90U/4.T | -                                                    | -     | 33000 | 31000 | 28500 | 26000 | 24000 |

## DIMENSIONS

| MODEL        | DIMENSIONS/ mm |     |      |         |     |   |
|--------------|----------------|-----|------|---------|-----|---|
|              | ØDi            | ØTK | ØDA  | ZxØO    | L   | S |
| AITB 71U/4.T | 710            | 751 | 812  | 16 x 14 | 670 | 3 |
| AITB 80U/4.T | 805            | 837 | 904  | 16 x 14 | 670 | 3 |
| AITB 90U/4.T | 900            | 934 | 1004 | 16 x 14 | 800 | 3 |

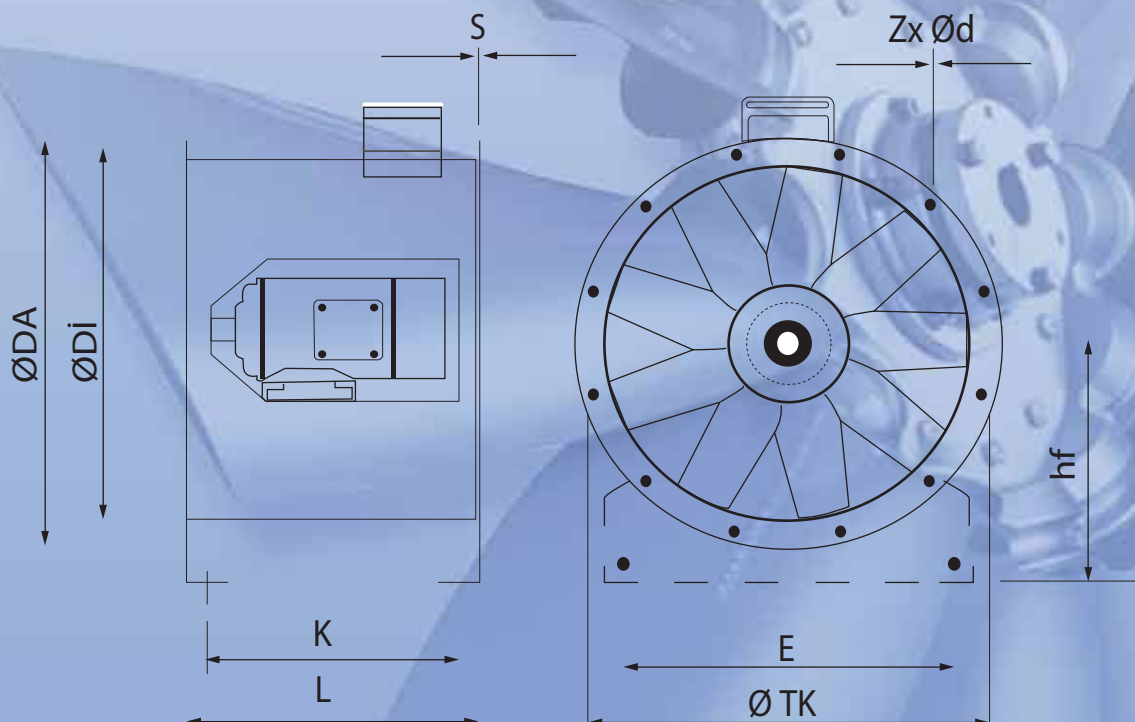

ACCESSORIES CONNECTION DIAGRAMS

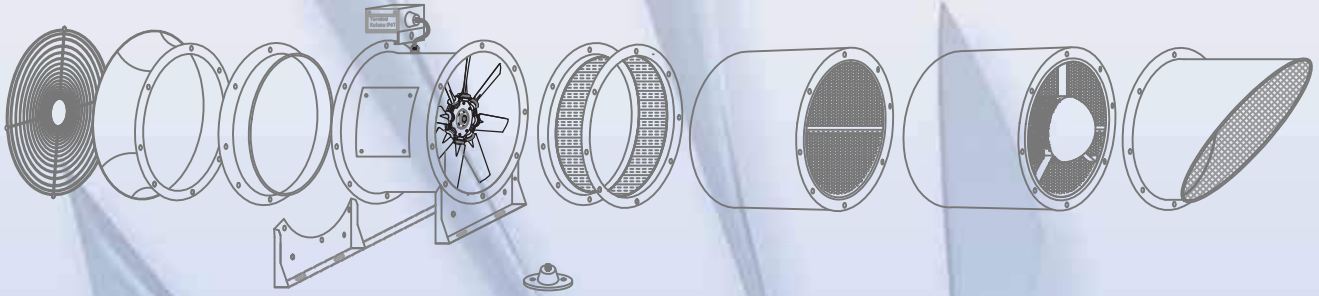



### Step 2 - Identify Fan Selection and Spacing

Table 5 shows the maximum and recommended spacings between JetVent Fans for different levels of fan thrust. These spacing distances are guidelines for fans placed in series. When using these spacings, air velocities in most of the ventilated areas should be greater than 1m/s. Analysis will determine whether this is achieved in a particular car park design. In some ideal cases, designs using the maximum distances have been effective.

Fan thrust depends on the operating speed of a particular fan unit and its thrust rating. See tables one to four for the thrust ratings of various fan models at different speeds.

| Operating fan thrust | Recommended fan to fan spacing distance | Maximum fan to fan spacing distance | Approximate coverage area |
|----------------------|-----------------------------------------|-------------------------------------|---------------------------|
| 50N                  | 45m                                     | 60m                                 | 100m <sup>2</sup>         |
| 28N                  | 34m                                     | 45m                                 | 560m <sup>2</sup>         |
| 25N                  | 30m                                     | 40m                                 | 500m <sup>2</sup>         |
| 19N                  | 23m                                     | 30m                                 | 380m <sup>2</sup>         |
| 12N                  | 12m                                     | 20m                                 | 250m <sup>2</sup>         |

Table 5. Fan spacing and coverage

Note that using fewer higher rated JetVent fans generally makes the system more cost effective than using more lower rated fans. However, to effectively ventilate car parks with unusual or irregularly shaped geometries, selecting more fans with smaller thrust ratings may be necessary.

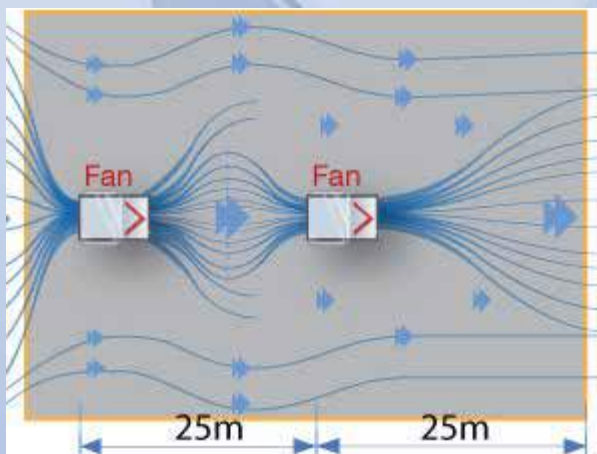

Figure 11(a). Two 25N fans

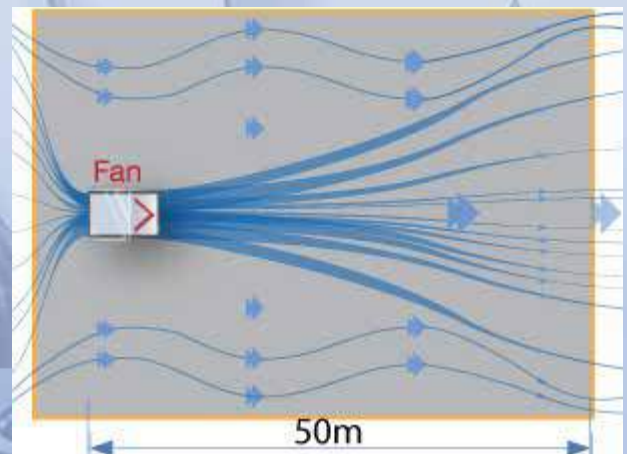

Figure 11(b). One 50N fan

### Step 3 - Design Example

For the purpose of estimating costs, the steps below may be bypassed. Allow 5N of thrust per 100m<sup>2</sup> of car park floor area to approximate the number of fans required. Fans should be placed in the laneways with the air blowing along them. This will ensure that the high air velocities close to the outlet nozzle do not significantly disturb pedestrian traffic as velocities will be lower at the lane edges. Also, ensure that the throw pattern of the selected fan is long enough to reach the next impulse fan.

Figure 12 shows an example of how fans are sized and placed based on floor area.



Figure 12. Fan sizing and placement example

## BOX SERIES

### Rectangulars Type Centrifugal Fans



#### USE

- Supply and exhaust ventilation systems installed in various premises.
- Compatible with 290 x 150 up to 400 x 300 mm rectangular air ducts.

#### MOTOR

- Two or four pole asynchronous motor with external rotor and centrifugal impeller with backward curved blades.
- Equipped with ball bearings for longer service life.
- Dynamically balanced turbine.
- Overheating protection by built-in thermal switches with automatic restart or with leaded outside terminals for connection to external protecting controls.
- The thermal switch terminal leads are designed for connection to respective circuit of the contactor, overload relay or respective terminals of the autotransformer or thyristor speed controller.

#### MOUNTING

- The fan is designed for mounting inside rectangular air ducts and can be installed in any position.
- The fan flanges are connected to the air ducts through the bolts inserted into the flange holes.
- The fan suitable for mounting into round duct at intake flange with a round reducer (available upon separate order.)

#### TECHNICAL SPECIFICATIONS

| MODEL    | MAX. AIR FLOW (m <sup>3</sup> /h) | Watt | SOUND (dBA) | AMPER | RPM (dk) | PRICE |
|----------|-----------------------------------|------|-------------|-------|----------|-------|
| BOX 600  | 575                               | 110  | 65          | 0,52  | 1250     | 154 € |
| BOX 1000 | 1100                              | 110  | 72          | 0,52  | 2600     | 198 € |
| BOX 1500 | 1500                              | 160  | 73          | 0,75  | 2500     | 220 € |
| BOX 2100 | 2100                              | 190  | 74          | 0,90  | 2500     | 244 € |

#### AIR FLOW PERFORMANCE DATA

| MODEL    | AIR FLOW PERFORMANCE DATA / PA / (m <sup>3</sup> /h) |      |      |      |      |      |      |     |     |
|----------|------------------------------------------------------|------|------|------|------|------|------|-----|-----|
|          | 100                                                  | 150  | 200  | 250  | 300  | 350  | 400  | 500 | 600 |
| BOX 600  | 500                                                  | 400  | -    | -    | -    | -    | -    | -   | -   |
| BOX 1000 | 900                                                  | 700  | 600  | 400  | 300  | 150  | -    | -   | -   |
| BOX 1500 | 1300                                                 | 1200 | 1100 | 900  | 700  | 600  | 400  | -   | -   |
| BOX 2100 | 1850                                                 | 1750 | 1700 | 1600 | 1500 | 1300 | 1200 | 900 | 400 |

## AIR FLOW PERFORMANCE DATA

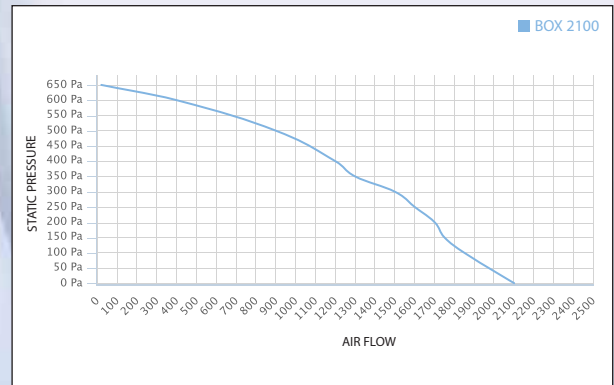
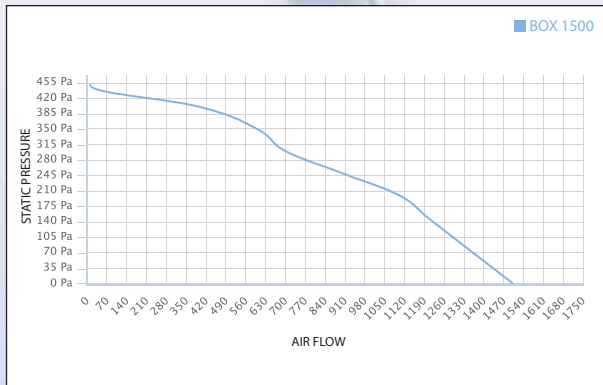
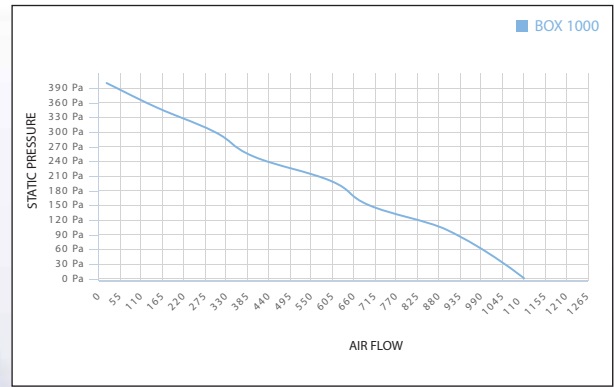
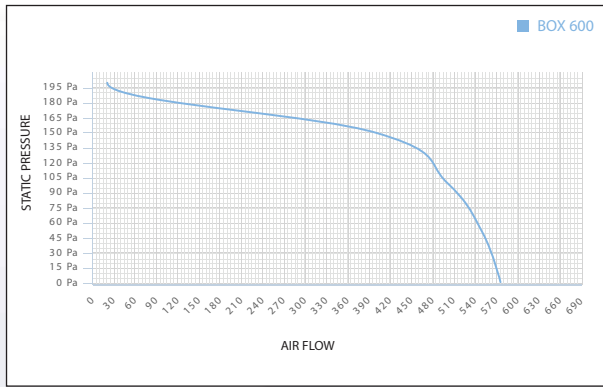

## DIMENSIONS

| MODEL    | DIMENSIONS / mm |     |     |     |     |     |     |      |
|----------|-----------------|-----|-----|-----|-----|-----|-----|------|
|          | A               | B   | C   | D   | E   | F   | G   | ØH   |
| BOX 600  | 290             | 150 | 320 | 170 | 340 | 200 | 350 | 10   |
| BOX 1000 | 300             | 200 | 325 | 225 | 350 | 250 | 460 | 12.5 |
| BOX 1500 | 400             | 200 | 425 | 225 | 450 | 250 | 460 | 12.5 |
| BOX 2100 | 400             | 300 | 425 | 325 | 450 | 350 | 600 | 12.5 |

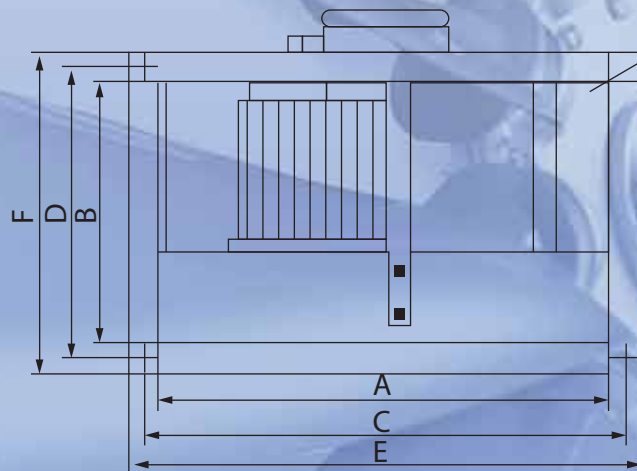

## ACCESSORIES

| MODEL    | SPEED CONTROLLER         |
|----------|--------------------------|
| RS-1-400 | TECHNICAL SPECIFICATIONS |

RS-1-400

Electronic, Maximum 1.8 Amper

## VKPF SERIES

### Rectangulars Type Centrifugal Fans



#### USE

- Supply and exhaust ventilation systems installed in various premises.
- Compatible with 500 x 300 up to 900 x 500 mm rectangular air ducts.

#### MOTOR

- Two or four pole asynchronous motor with external rotor and centrifugal impeller with backward curved blades.
- Equipped with ball bearings for longer service life.
- Dynamically balanced turbine.
- Overheating protection by built-in thermal switches with automatic restart or with leaded outside terminals for connection to external protecting controls.
- The thermal switch terminal leads are designed for connection to respective circuit of the contactor, overload relay or respective terminals of the autotransformer or thyristor speed controller.

#### MOUNTING

- The fan is designed for mounting inside rectangular air ducts and can be installed in any position.
- The fan flanges are connected to the air ducts through the bolts inserted into the flange holes.
- The fan suitable for mounting into round duct at intake flange with a round reducer (available upon separate order.)

#### TECHNICAL SPECIFICATIONS

| MODEL             | MAX. AIR FLOW (m <sup>3</sup> /h) | WATT  | SOUND (dBA) | AMPER | RPM (dk) | PRICE  |
|-------------------|-----------------------------------|-------|-------------|-------|----------|--------|
| VKPF 4E 500 x 300 | 2350                              | 710   | 57          | 3,10  | 1.230    | 462 €  |
| VKPF 4D 600 x 300 | 3740                              | 1.560 | 57          | 2,73  | 1.310    | 605 €  |
| VKPF 4D 600 x 350 | 5020                              | 2.460 | 60          | 3,93  | 1.300    | 726 €  |
| VKPF 4D 700 x 400 | 6450                              | 3.630 | 65          | 6,00  | 1.320    | 980 €  |
| VKPF 4D 800 x 500 | 8120                              | 5.850 | 67          | 9,35  | 1.140    | 1188 € |
| VKPF 6D 900 x 500 | 9540                              | 3870  | 61          | 7,00  | 930      | 1265 € |

#### AIR FLOW PERFORMANCE DATA

| MODEL             | AIR FLOW PERFORMANCE DATA / PA / (m <sup>3</sup> /h) |      |      |      |      |      |      |      |      |  |
|-------------------|------------------------------------------------------|------|------|------|------|------|------|------|------|--|
|                   | 200                                                  | 300  | 400  | 500  | 600  | 700  | 800  | 900  | 1000 |  |
| VKPF 4E 500 x 300 | 1750                                                 | 1200 | -    | -    | -    | -    | -    | -    | -    |  |
| VKPF 4D 600 x 300 | 3300                                                 | 3000 | 2500 | -    | -    | -    | -    | -    | -    |  |
| VKPF 4D 600 x 350 | 4800                                                 | 4500 | 4000 | 3000 | 1520 | -    | -    | -    | -    |  |
| VKPF 4D 700 x 400 | -                                                    | 6200 | 5800 | 5400 | 5000 | 4010 | 2020 | -    | -    |  |
| VKPF 4D 800 x 500 | -                                                    | 8000 | 7700 | 7200 | 7000 | 6030 | 5500 | 4000 | 2010 |  |
| VKPF 6D 900 x 500 | 9200                                                 | 8800 | 8000 | 7010 | 5050 | -    | -    | -    | -    |  |

## AIR FLOW PERFORMANCE DATA

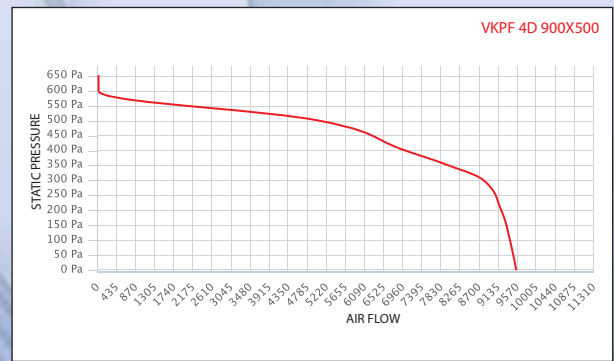
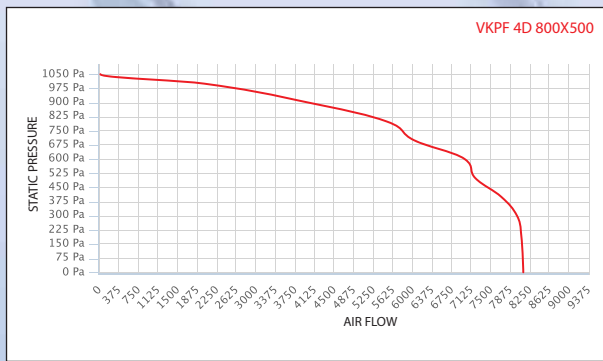
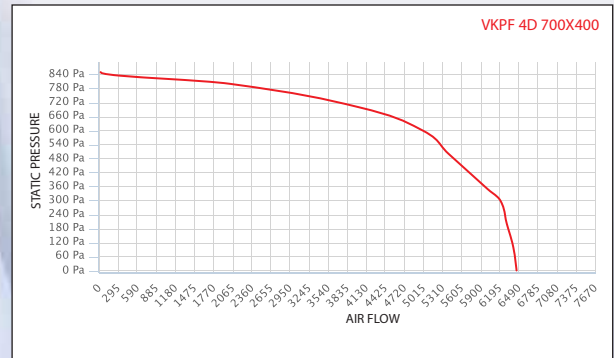
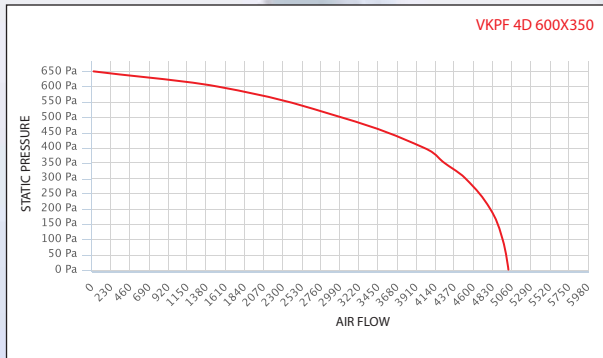
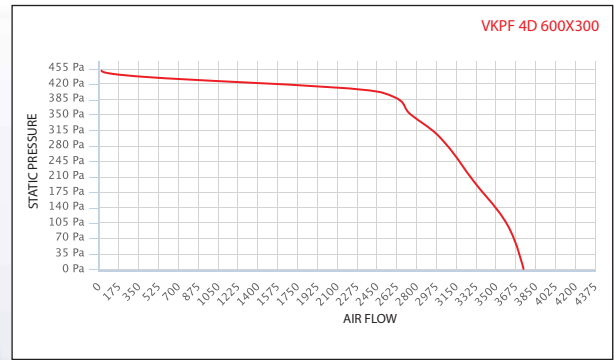
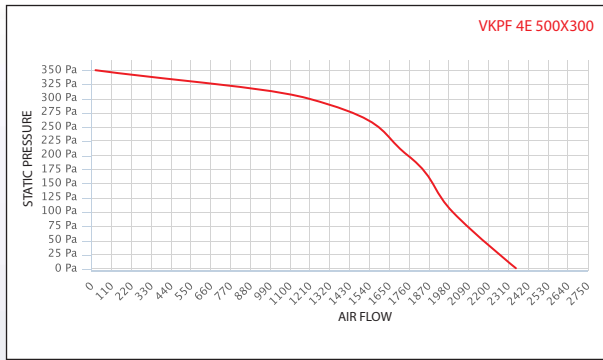

## DIMENSIONS

| MODEL             | DIMENSIONS/ mm |     |     |     |     |     |     |     |        |
|-------------------|----------------|-----|-----|-----|-----|-----|-----|-----|--------|
|                   | B              | B1  | B2  | H   | H1  | H2  | H3  | L   | WEIGHT |
| VKPF 4E 500 x 300 | 500            | 520 | 540 | 300 | 320 | 340 | 365 | 680 | 33,0   |
| VKPF 4D 600 x 300 | 600            | 620 | 640 | 300 | 320 | 340 | 375 | 680 | 35,0   |
| VKPF 4D 600 x 350 | 600            | 620 | 640 | 350 | 370 | 390 | 425 | 735 | 49,5   |
| VKPF 4D 700 x 400 | 700            | 720 | 740 | 400 | 420 | 440 | 480 | 780 | 60,0   |
| VKPF 4D 800 x 500 | 800            | 820 | 840 | 500 | 520 | 540 | 580 | 820 | 74,0   |
| VKPF 6D 900 x 500 | 900            | 920 | 940 | 500 | 520 | 540 | 580 | 954 | 90,0   |

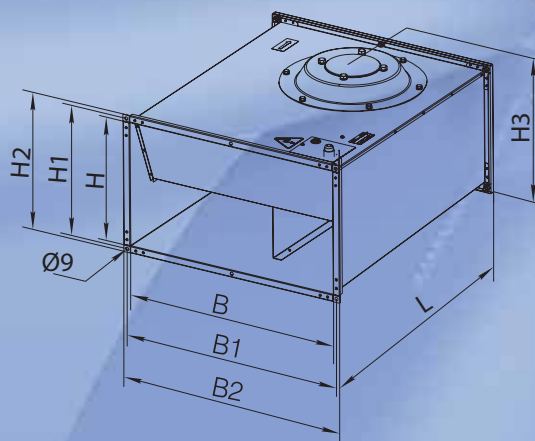

## PRF Series

Rectangular Type Centrifugal Fans With External Motor



190 °C

### Fan:

- Galvanised sheet steel structure.
- Impeller with reaction blades made of sheet steel.
- Approved in accordance with standard EN 12101-3. with certificate no.: 0370-CPR-0594.
- Linear air flow direction.

### Motor:

- Class F motors with ball bearings. IP55 protection and with 1 or 2 speeds. depending on model.
- IE3 efficiency motors for powers equal to or greater than 0.75kW except single-phase. 2-speed and 8-pole.
- Three-phase 230/400V-50Hz (up to 4kW) and 400/690V-50Hz (powers higher than 4kW).
- Maximum temperature of air to be carried:  
S1 continuous operation -20°C +120°C.

### Finish:

- Anticorrosive galvanised sheet steel.

### On request:

- Extractor fans with 2-speed motors.

TECHNICAL SPECIFICATIONS

| MODEL   | MAX. AIR FLOW (m <sup>3</sup> /h) | WATT | SOUND (dBA) | AMPER | RPM (dk) | PRICE  |
|---------|-----------------------------------|------|-------------|-------|----------|--------|
| 31B/4T  | 2450                              | 0,25 | 70          | 0,80  | 1450     | 835 €  |
| 35B/4T  | 3500                              | 0,37 | 74          | 1,20  | 1450     | 910 €  |
| 40B/4T  | 5000                              | 0,75 | 76          | 2,10  | 1450     | 1125 € |
| 45B/4T  | 7300                              | 1,50 | 80          | 2,20  | 1450     | 1348 € |
| 50B/4T  | 10500                             | 2,20 | 84          | 2,20  | 1450     | 1552 € |
| 56B/4T  | 13000                             | 3,00 | 88          | 3,00  | 1450     | 1872 € |
| 63B/4T  | 18500                             | 4,00 | 92          | 4,00  | 1450     | 2247 € |
| 71B/4T  | 27500                             | 7,50 | 94          | 7,50  | 1450     | 2782 € |
| 31B/2.T | 5000                              | 1,10 | 84          | 1,10  | 2950     | 1230 € |
| 35B/2.T | 7000                              | 2,20 | 88          | 2,20  | 2950     | 1390 € |
| 40B/2.T | 9500                              | 4,00 | 92          | 4,00  | 2950     | 1960 € |
| 45B/2.T | 13800                             | 7,50 | 96          | 7,50  | 2950     | 2150 € |
| 56B/6T  | 7500                              | 1,50 | 80          | 1,50  | 1000     | 1872 € |
| 63B/6T  | 12000                             | 2,20 | 82          | 2,20  | 1000     | 2195 € |
| 71B/6T  | 17000                             | 3,00 | 84          | 3,00  | 1000     | 2568 € |
| 80B/6T  | 25000                             | 4,00 | 87          | 4,00  | 1000     | 3425 € |

AIR FLOW PERFORMANCE DATA

| MODEL           | AIR FLOW PERFORMANCE DATA/ PA / (m <sup>3</sup> /h) |            |            |            |             |             |             |             |             |             |
|-----------------|-----------------------------------------------------|------------|------------|------------|-------------|-------------|-------------|-------------|-------------|-------------|
|                 | 50                                                  | 100        | 150        | 200        | 300         | 350         | 400         | 500         | 600         | 1200        |
| PRF 31B/4T      | 2450                                                | 2200       | 2000       | 1850       | 1000        | -           | -           | -           | -           | -           |
| PRF 35B/4T      | -                                                   | 3500       | 3000       | 2700       | 2200        | 1500        | -           | -           | -           | -           |
| PRF 40B/4T      | -                                                   | 5000       | 4700       | 4500       | 3700        | 3400        | -           | -           | -           | -           |
| PRF 45B/4T      | -                                                   | 7300       | 7100       | 6900       | 6400        | 6100        | 5700        | -           | -           | -           |
| PRF 50B/4T      | -                                                   | -          | 10500      | 10000      | 9300        | 8900        | 8400        | 7500        | -           | -           |
| PRF 56B/4T      | -                                                   | -          | -          | 13000      | 12500       | 12000       | 11500       | 11000       | 9000        | -           |
| PRF 63B/4T      | -                                                   | -          | -          | -          | 18500       | 18500       | 18000       | 17000       | 16000       | -           |
| PRF 71B/4T      | -                                                   | -          | -          | -          | -           | -           | 27500       | 26500       | 25000       | 16500       |
| <b>2950 d/d</b> | <b>200</b>                                          | <b>400</b> | <b>600</b> | <b>800</b> | <b>1000</b> | <b>1200</b> | <b>1400</b> | <b>1600</b> | <b>1800</b> | <b>2000</b> |
| PRF 31B/2.T     | 5000                                                | 4400       | 4000       | 3500       | 2900        | -           | -           | -           | -           | -           |
| PRF 35B/2.T     | 7000                                                | 6500       | 6000       | 5500       | 5000        | 4000        | -           | -           | -           | -           |
| PRF 40B/2.T     | -                                                   | -          | 9500       | 9300       | 8900        | 8400        | 7700        | 7000        | 5700        | 4500        |
| PRF 45B/2.T     | -                                                   | -          | 13800      | 1300       | 12500       | 12000       | 11500       | 11000       | 10000       | 9000        |
| <b>1000 d/d</b> | <b>200</b>                                          | <b>250</b> | <b>300</b> | <b>350</b> | <b>400</b>  | <b>450</b>  | <b>500</b>  | <b>550</b>  | <b>650</b>  | <b>700</b>  |
| PRF 56B/6T      | 7500                                                | 7000       | 6500       | 5750       | 5000        | 4500        | -           | -           | -           | -           |
| PRF 63B/6T      | 12000                                               | 11750      | 11500      | 10750      | 8900        | 8900        | 7500        | 7000        | 5000        | -           |
| PRF 71B/6T      | 17000                                               | 16500      | 16000      | 15000      | 13000       | 13000       | 11500       | 11000       | 8000        | -           |
| PRF 80B/6T      | 25000                                               | 24300      | 23500      | 22700      | 21000       | 21000       | 20000       | 19500       | 18000       | 16500       |

# TECHNICAL SPECIFICATIONS

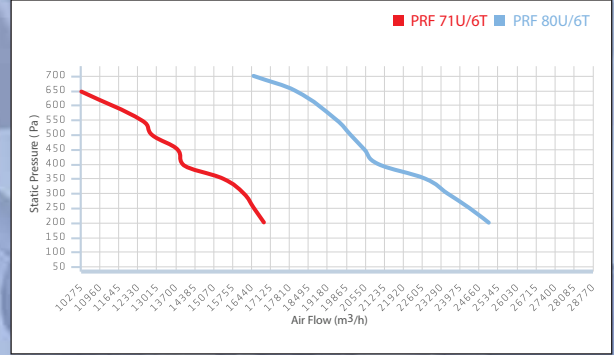
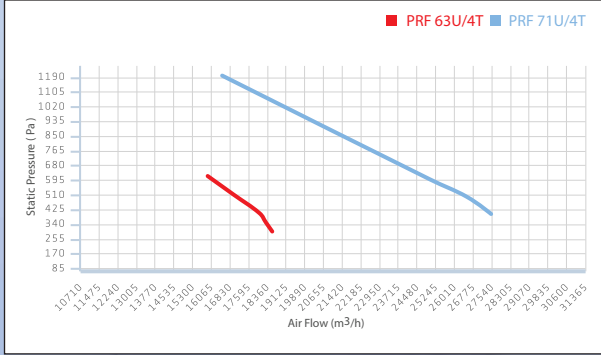
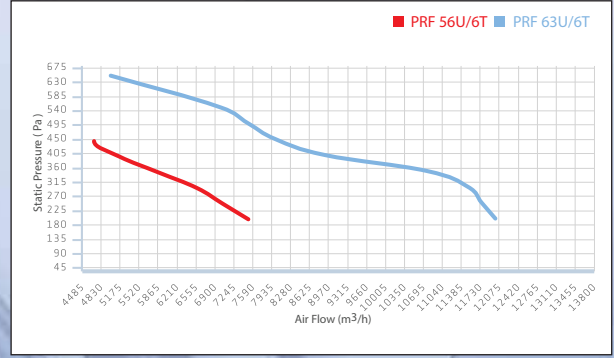
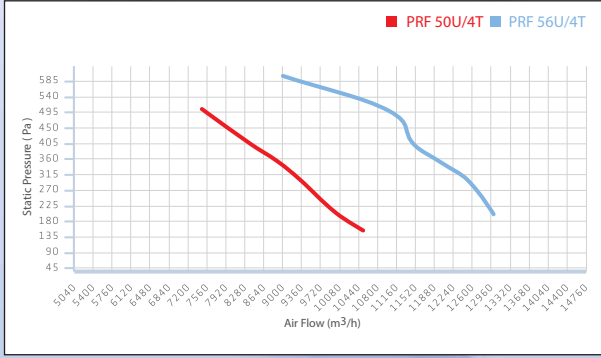
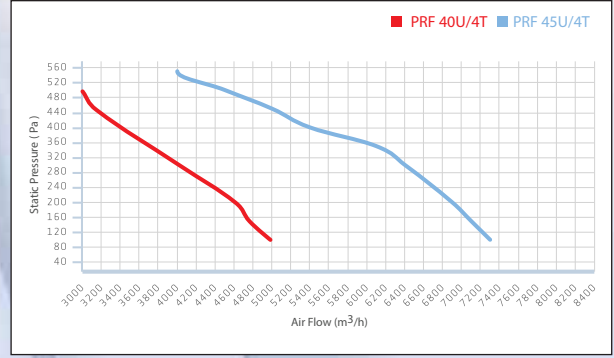
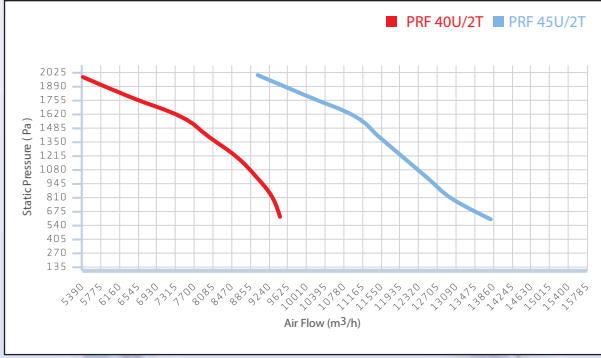
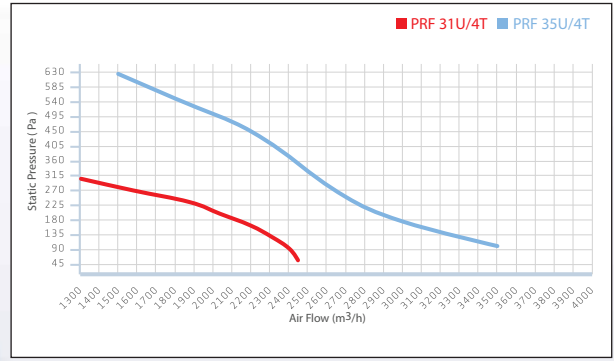
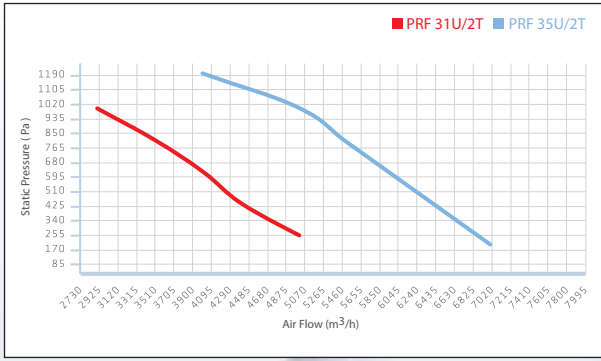

## DIMENSIONS

| MODEL         | DIMENSIONS/ mm |     |      |     | FILTER DIMENSIONS / mm |     |     |
|---------------|----------------|-----|------|-----|------------------------|-----|-----|
|               | a              | b   | L    | h   | a                      | b   | L   |
| PRF 31B/2/4/6 | 600            | 400 | 600  | 270 | 600                    | 400 | 400 |
| PRF 35B/2/4/6 | 600            | 400 | 600  | 300 | 600                    | 400 | 400 |
| PRF 40B/2/4/6 | 600            | 400 | 600  | 325 | 600                    | 400 | 400 |
| PRF 45B/2/4/6 | 800            | 500 | 800  | 340 | 800                    | 500 | 400 |
| PRF 50B/2/4/6 | 900            | 600 | 840  | 375 | 900                    | 600 | 600 |
| PRF 56B/2/4/6 | 900            | 600 | 840  | 390 | 900                    | 600 | 600 |
| PRF 63B/2/4/6 | 900            | 600 | 840  | 430 | 900                    | 600 | 600 |
| PRF 71B/4/6   | 1200           | 800 | 840  | 380 | 1200                   | 800 | 600 |
| PRF 80B/4/6   | 1200           | 800 | 1070 | 430 | 1200                   | 800 | 800 |



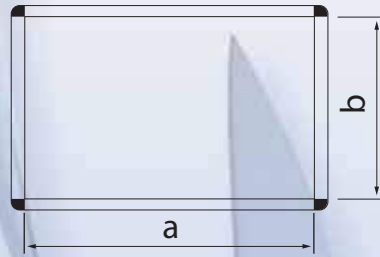
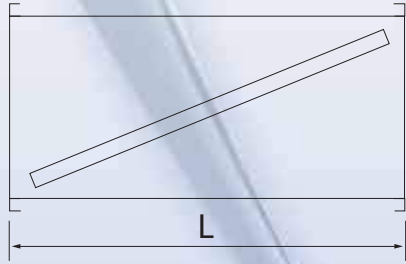
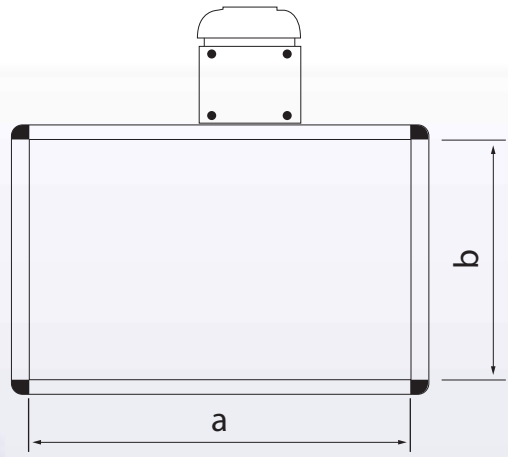
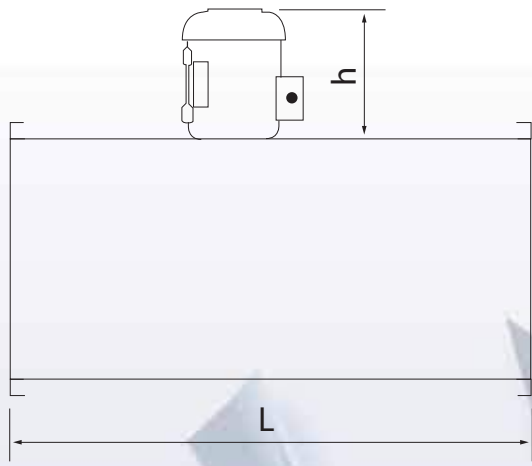

## ACCESSORIES



Silencer



Active Carbon Filter

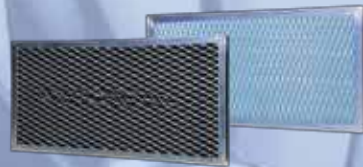

Iron Grease Filter

**SIT Series**  
Sound Insulated  
Axial Fans

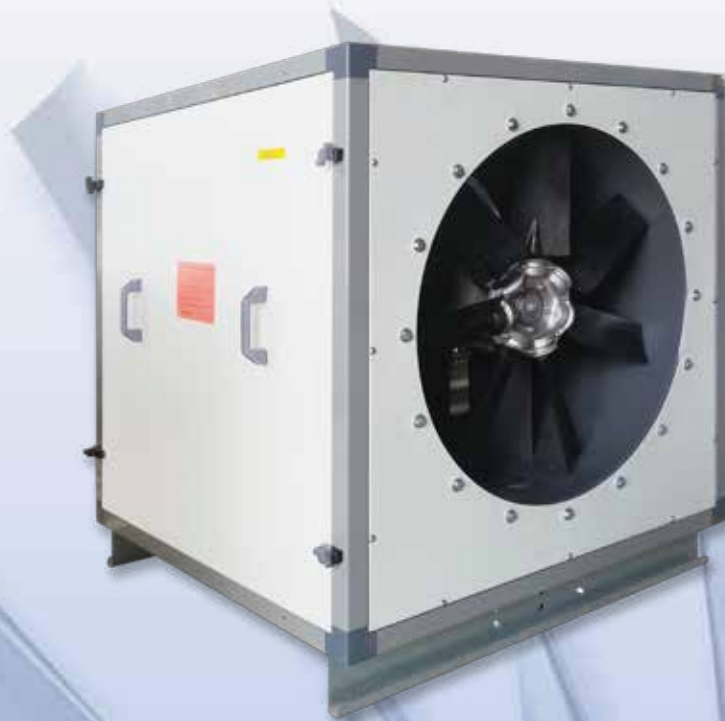

**FAN**

- Galvanized sheet steel structure with thermal and acoustic insulation.
- Fibreglass-reinforced polyamide 6 rotors.
- Ventilation units prepared for vertical or horizontal operation.
- Motor-rotor air flow direction

**MOTOR**

- IE3 efficiency motors for powers equal to or greater than 0,18 Kw expect single-phase. 2-speed and 8-pole.
- Class F motors with ball bearings and IP55 protection expect single phase. From size 35 to 45 with IP 54 protection. 1 or 2 speeds depending on model.
- Single-phase 230V-50Hz and three-phase 230/400V-50Hz and 400/690V-50Hz (power greater than 4 Kw)
- Operating temperature -25°C + 55°C

TECHNICAL SPECIFICATIONS

| MODEL     | MAX. AIR FLOW (m <sup>3</sup> /h) | WATT  | SOUND (dBA) | RPM (dk) | PRICE  |
|-----------|-----------------------------------|-------|-------------|----------|--------|
| 35U/4.T   | 3100                              | 0,18  | 72          | 1450     | 602 €  |
| 40U/4.T   | 5000                              | 0,25  | 76          | 1450     | 660 €  |
| 45U/4.T   | 5800                              | 0,37  | 78          | 1450     | 682 €  |
| 50U/4.T   | 7000                              | 0,55  | 79          | 1450     | 787 €  |
| 63U/4.T   | 11500                             | 0,75  | 81          | 1450     | 952 €  |
| 63U/4.T1  | 14000                             | 1,50  | 85          | 1450     | 1145 € |
| 63U/4.T2  | 17000                             | 2,20  | 88          | 1450     | 1193 € |
| 63U/4.T3  | 22000                             | 3,00  | 92          | 1450     | 1300 € |
| 35U/2.T   | 5500                              | 1,10  | 89          | 2950     | 772 €  |
| 40U/2.T   | 8000                              | 1,50  | 92          | 2950     | 975 €  |
| 45U/2.T   | 11000                             | 3,00  | 95          | 2950     | 1165 € |
| 50U/2.T   | 14000                             | 4,00  | 96          | 2950     | 1360 € |
| 63U/2.T   | 22700                             | 7,50  | 98          | 2950     | 1660 € |
| 71U/4.T   | 24000                             | 4,00  | 91          | 1450     | 1427 € |
| 80U/4.T   | 28000                             | 5,50  | 92          | 1450     | 1778 € |
| 80U/4.T1  | 33000                             | 7,50  | 96          | 1450     | 1896 € |
| 90U/4.T   | 29000                             | 3,00  | 89          | 1450     | 1627 € |
| 90U/4.T1  | 40000                             | 7,50  | 96          | 1450     | 2012 € |
| 100U/4.T  | 43000                             | 7,50  | 93          | 1450     | 2289 € |
| 100U/4.T1 | 50000                             | 11,00 | 97          | 1450     | 2514 € |
| 125U/4.T  | 61000                             | 15,00 | 95          | 1450     | 3024 € |
| 125U/4.T1 | 88000                             | 30,00 | 101         | 1450     | 3935 € |

AIR FLOW PERFORMANCE DATA

| MODEL    | AIR FLOW PERFORMANCE DATA / PA / (m <sup>3</sup> /h) |      |       |       |       |       |       |       |       |       |     |
|----------|------------------------------------------------------|------|-------|-------|-------|-------|-------|-------|-------|-------|-----|
|          | 1400 d/d                                             | 0    | 25    | 50    | 75    | 100   | 125   | 150   | 175   | 200   | 250 |
| 35U/4.T  | 3100                                                 | 2700 | 2350  | 2000  | -     | -     | -     | -     | -     | -     | -   |
| 40U/4.T  | 5000                                                 | 4500 | 4100  | 3500  | 3150  | 2650  | -     | -     | -     | -     | -   |
| 45U/4.T  | -                                                    | 5800 | 5350  | 5000  | 4650  | 4100  | 3350  | -     | -     | -     | -   |
| 50U/4.T  | -                                                    | -    | 7000  | 6550  | 6150  | 5700  | 5000  | -     | -     | -     | -   |
| 63U/4.T  | -                                                    | -    | 11500 | 11000 | 10400 | 9750  | 9000  | 8100  | 7100  | -     | -   |
| 63U/4.T1 | -                                                    | -    | -     | 14000 | 13500 | 13000 | 12500 | 12000 | 11500 | 9500  | -   |
| 63U/4.T2 | -                                                    | -    | -     | 17000 | 16500 | 16000 | 15500 | 15000 | 14500 | 13000 | -   |
| 63U/4.T3 | -                                                    | -    | -     | 22000 | 20500 | 20000 | 19500 | 18800 | 18000 | 16000 | -   |

AIR FLOW PERFORMANCE DATA

| MODEL     | AIR FLOW PERFORMANCE DATA / PA / (m <sup>3</sup> /h) |       |       |       |       |       |       |       |       |       |     |
|-----------|------------------------------------------------------|-------|-------|-------|-------|-------|-------|-------|-------|-------|-----|
|           | 2800 d/d                                             | 100   | 150   | 200   | 250   | 300   | 400   | 500   | 600   | 700   | 800 |
| 35U/2.T   | -                                                    | 5500  | 5235  | 5000  | 4750  | 4100  | -     | -     | -     | -     | -   |
| 40U/2.T   | -                                                    | -     | 8000  | 7600  | 7300  | 6550  | 5710  | 3510  | -     | -     | -   |
| 45U/2.T   | -                                                    | -     | -     | 11000 | 10400 | 9700  | 8750  | 7300  | -     | -     | -   |
| 50U/2.T   | -                                                    | -     | -     | 14000 | 13600 | 13000 | 11900 | 10550 | 8900  | -     | -   |
| 63U/2.T   | -                                                    | -     | -     | -     | 22700 | 21600 | 20350 | 18900 | 17200 | 15400 | -   |
| 71U/4.T   | -                                                    | -     | 24000 | 19000 | 16000 | -     | -     | -     | -     | -     | -   |
| 80U/4.T   | 28000                                                | 28000 | 26500 | 25000 | 20000 | 13000 | -     | -     | -     | -     | -   |
| 80U/4.T1  | -                                                    | -     | 33000 | 28000 | 25000 | 20000 | -     | -     | -     | -     | -   |
| 90U/4.T   | 29000                                                | 29000 | 26000 | 23500 | 20000 | 16000 | -     | -     | -     | -     | -   |
| 90U/4.T1  | -                                                    | -     | 40000 | 37000 | 34000 | 27500 | -     | -     | -     | -     | -   |
| 100U/4.T  | 43000                                                | 43000 | 41000 | 39000 | 37500 | 32000 | 25000 | 20000 | -     | -     | -   |
| 100U/4.T1 | -                                                    | -     | 50000 | 48000 | 46500 | 42000 | 35600 | 25000 | -     | -     | -   |
| 125U/4.T  | 61000                                                | 61000 | 60000 | 58000 | 56500 | 55000 | 52000 | 50000 | 45000 | 40000 | -   |
| 125U/4.T1 | -                                                    | -     | -     | 88000 | 85000 | 83000 | 79000 | 76000 | 71000 | 66000 | -   |

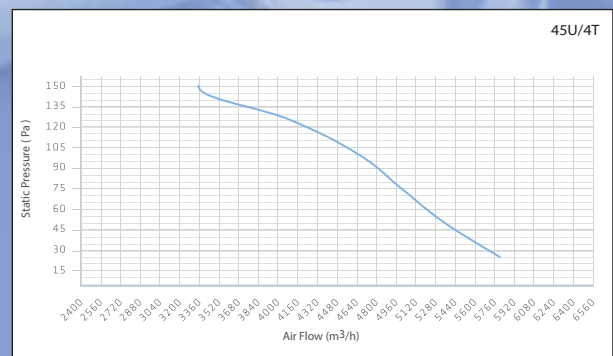
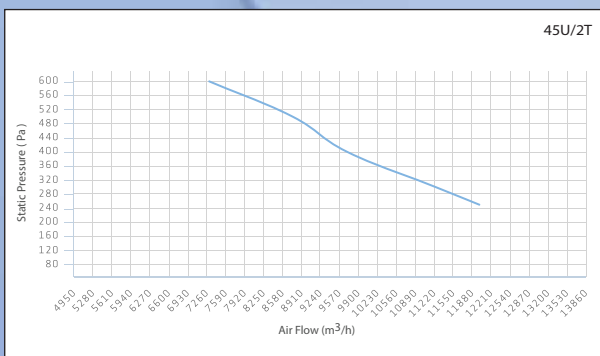
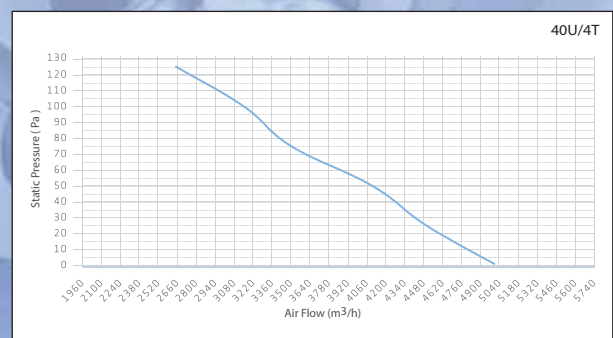
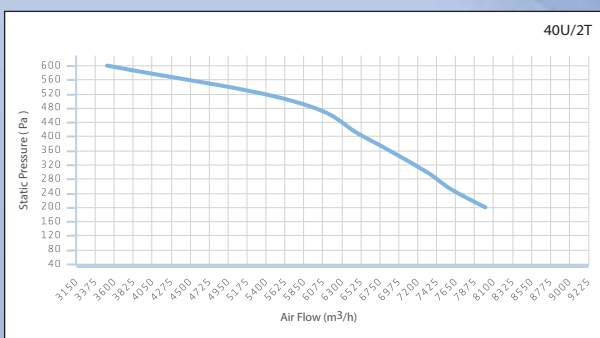
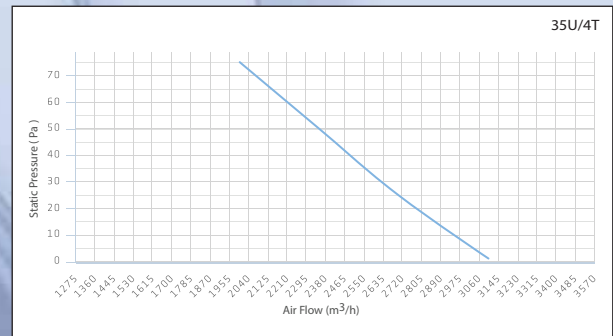
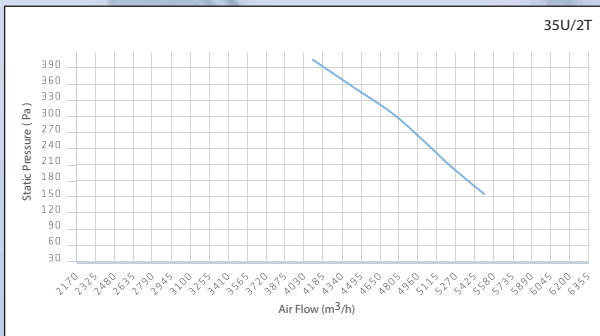

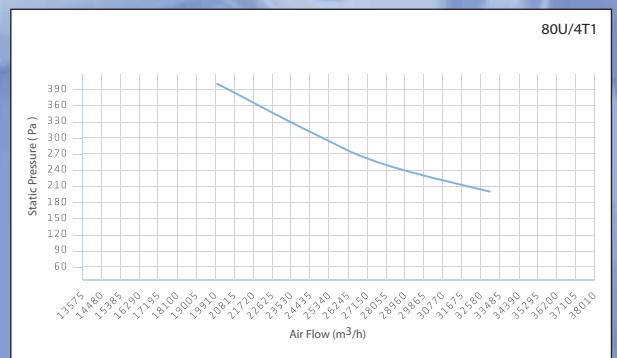
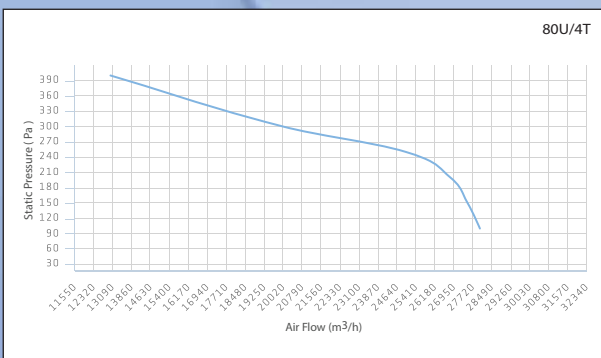
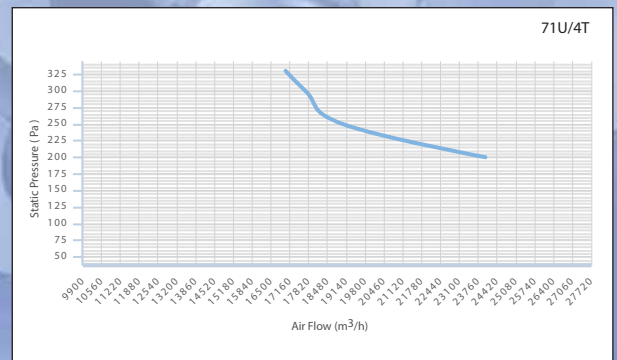
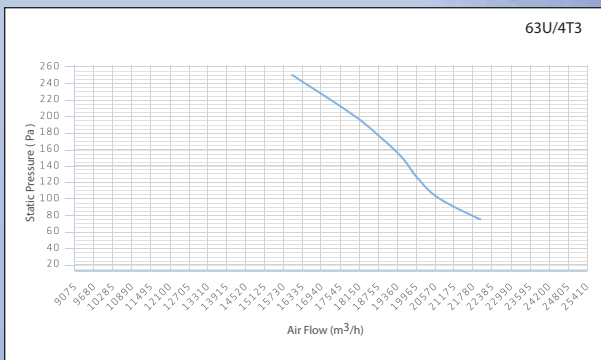
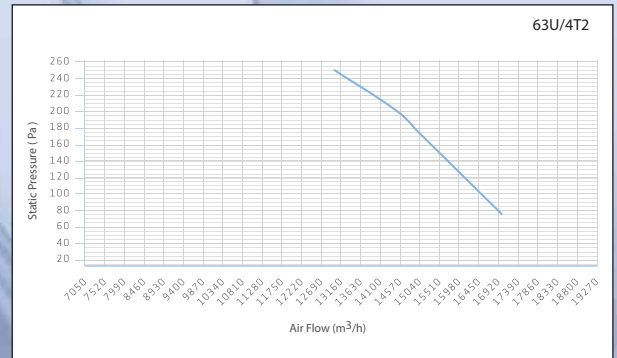
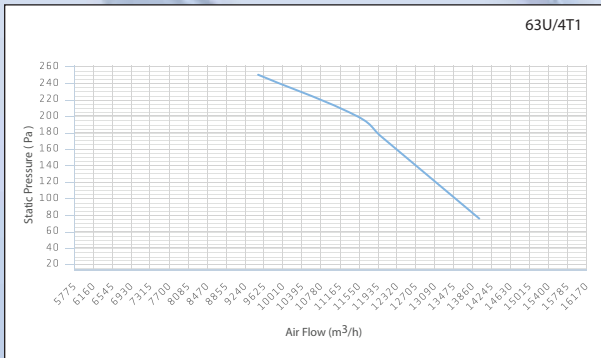
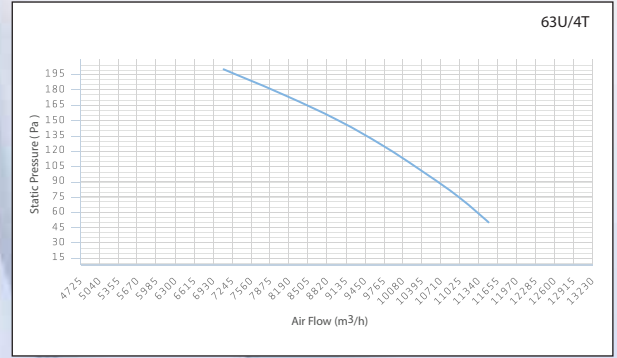
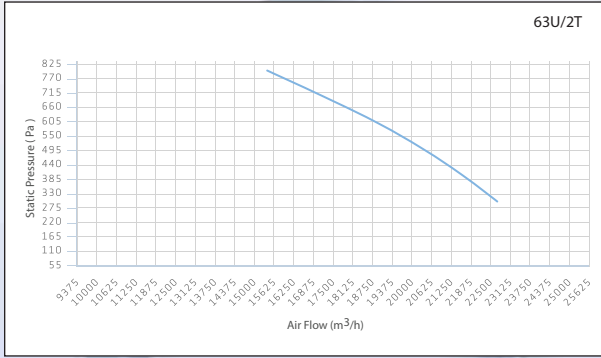
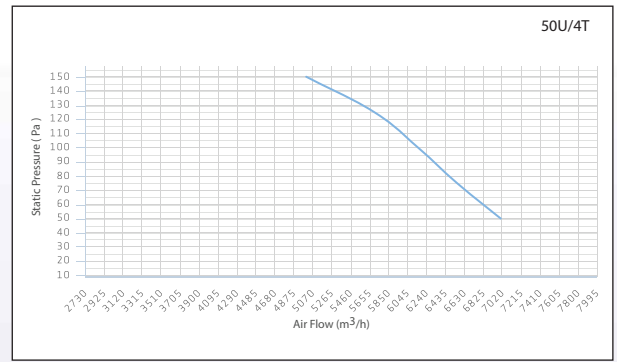
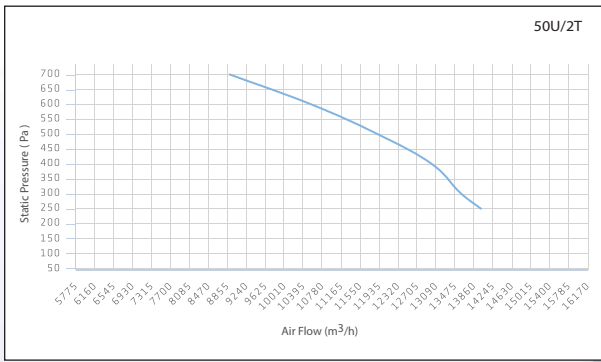

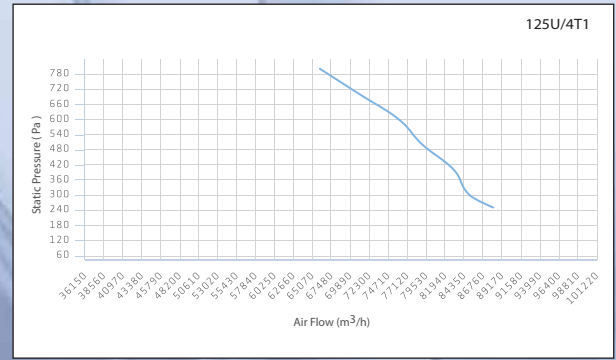
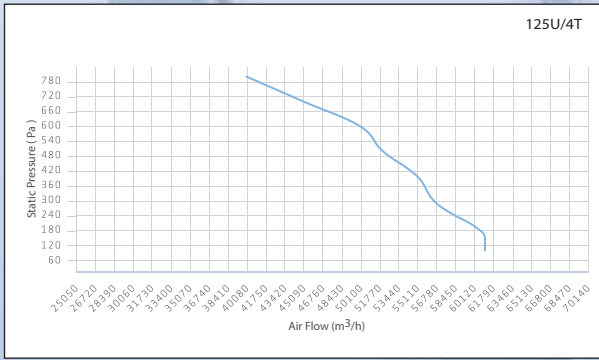
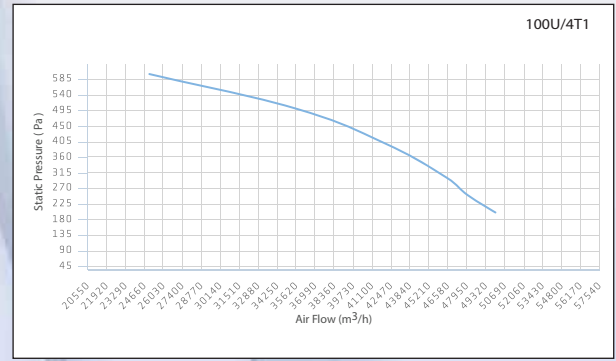
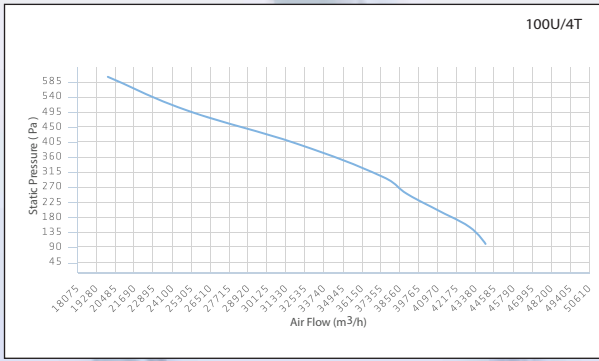
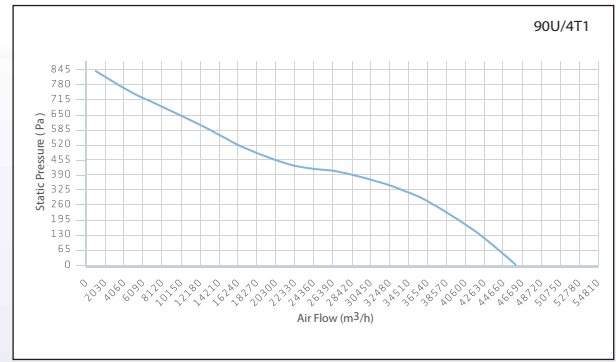
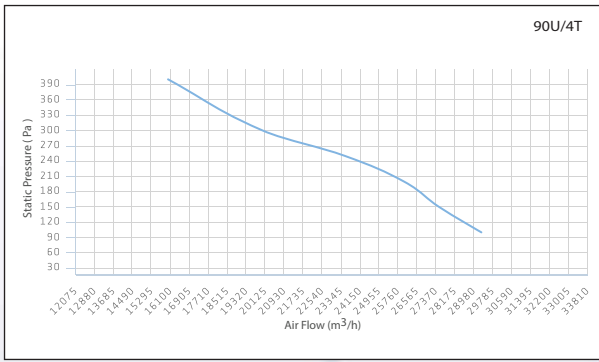

## DIMENSIONS

| MODEL    | DIMENSIONS/ mm  |      |      |         |     |   |     |
|----------|-----------------|------|------|---------|-----|---|-----|
|          | ØD <sub>i</sub> | ØTK  | ØDA  | ZxØd    | L   | S | hf  |
| SIT 35U  | 355             | 395  | 435  | 8 x 10  | 500 | 2 | 228 |
| SIT 40U  | 400             | 450  | 480  | 8 x 12  | 500 | 2 | 270 |
| SIT 45U  | 450             | 500  | 530  | 8 x 12  | 500 | 3 | 295 |
| SIT 50U  | 500             | 560  | 590  | 12 x 12 | 500 | 3 | 320 |
| SIT 63U  | 630             | 690  | 730  | 14 x 12 | 500 | 3 | 385 |
| SIT 71U  | 710             | 770  | 810  | 16 x 14 | 500 | 3 | 425 |
| SIT 80U  | 800             | 860  | 900  | 16 x 14 | 500 | 3 | 470 |
| SIT 90U  | 900             | 970  | 1000 | 16 x 15 | 500 | 4 | 550 |
| SIT 100U | 1000            | 1070 | 1100 | 16 x 15 | 500 | 4 | 600 |
| SIT 112U | 1120            | 1190 | 1220 | 24 x 15 | 750 | 4 | 760 |
| SIT 125U | 1250            | 1320 | 1370 | 24 x 15 | 750 | 6 | 725 |

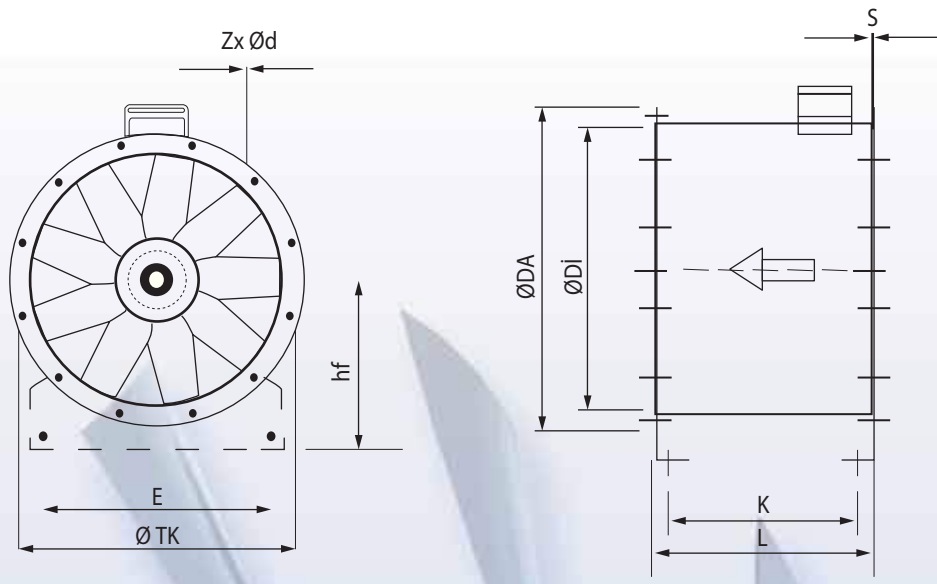

ACCESSORY CONNECTION DIAGRAM

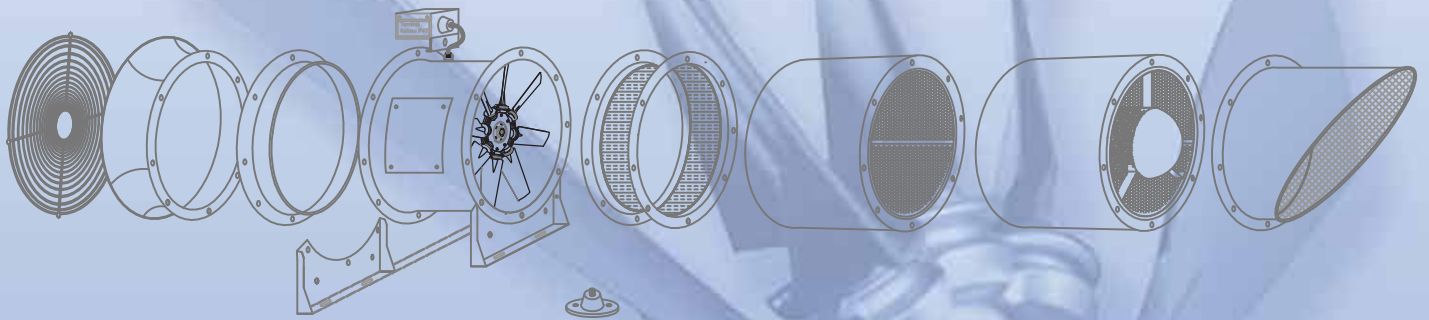

## SRT Series

### Sound Insulated Centrifugal Fans



120 °C

#### FAN

- Ventilation units fitted with double-inlet fans from the SRT series.
- Aluminium profiles structure with thermal and acoustic insulation.
- Impeller with forward-curved blades made of galvanised sheet steel.
- Cable gland for cable inlet.

#### MOTOR

- IE3 efficiency motors for powers equal to or greater than 0,75 Kw except single-phase. 2-speed and 8-pole.
- Class F motors with ball bearings and IP55 protection.
- Three-phase 230/400V-50Hz and 400/690V-50 Hz (powers higher than 4 Kw)
- Maximum temperature of air to be carried -20°C + 120°C

#### FINISH

- Anticorrosive pre-varnished sheet steel and aluminium profiles.

#### ON REQUEST

- With circular impulsion.



## TECHNICAL SPECIFICATIONS

| MODEL        | MAX. AIR FLOW (m <sup>3</sup> /h) | WATT | SOUND (dBA) | AMPER | RPM (dk) | PRICE  |
|--------------|-----------------------------------|------|-------------|-------|----------|--------|
| SRT 35B/4.T  | 3000                              | 0,37 | 72          | 0,80  | 1450     | 1390 € |
| SRT 40B/4.T  | 4500                              | 0,55 | 75          | 1,00  | 1450     | 1500 € |
| SRT 45B/4.T  | 6500                              | 1,00 | 80          | 2,00  | 1450     | 1875 € |
| SRT 50B/4.T  | 9000                              | 1,50 | 83          | 3,00  | 1450     | 2090 € |
| SRT 56B/4.T  | 12000                             | 2,50 | 85          | 7,00  | 1450     | 2355 € |
| SRT 63B/4.T  | 14500                             | 4,60 | 91          | 8,00  | 1450     | 2625 € |
| SRT 63B/4.T1 | 20500                             | 6,20 | 92          | 11,00 | 1450     | 3155 € |

## AIR FLOW PERFORMANCE DATA

| MODEL        | AIR FLOW PERFORMANCE DATA/ PA / (m <sup>3</sup> /h) |       |       |       |       |       |       |       |       |       |       |       |      |
|--------------|-----------------------------------------------------|-------|-------|-------|-------|-------|-------|-------|-------|-------|-------|-------|------|
|              | 1400 d/d                                            | 0     | 100   | 200   | 250   | 300   | 400   | 500   | 600   | 700   | 800   | 900   | 1000 |
| SRT 35B/4.T  | 3000                                                | 2500  | 2000  | 1500  | -     | -     | -     | -     | -     | -     | -     | -     | -    |
| SRT 40B/4.T  | 4500                                                | 4000  | 3200  | 2700  | 2500  | -     | -     | -     | -     | -     | -     | -     | -    |
| SRT 45B/4.T  | 6500                                                | 6000  | 5500  | 5200  | 4900  | 4000  | -     | -     | -     | -     | -     | -     | -    |
| SRT 50B/4.T  | 9000                                                | 8500  | 7900  | 7500  | 7000  | 6500  | 5500  | 4500  | -     | -     | -     | -     | -    |
| SRT 56B/4.T  | 12000                                               | 11500 | 10500 | 10200 | 9800  | 9200  | 8400  | 7900  | 6400  | -     | -     | -     | -    |
| SRT 63B/4.T  | 14500                                               | 14000 | 13750 | 13200 | 12700 | 12250 | 11800 | 11600 | 10500 | 9800  | 8600  | -     | -    |
| SRT 63B/4.T1 | 20500                                               | 20000 | 19600 | 19100 | 18700 | 18000 | 16750 | 16200 | 15300 | 14300 | 13200 | 11000 | -    |

## TECHNICAL SPECIFICATIONS

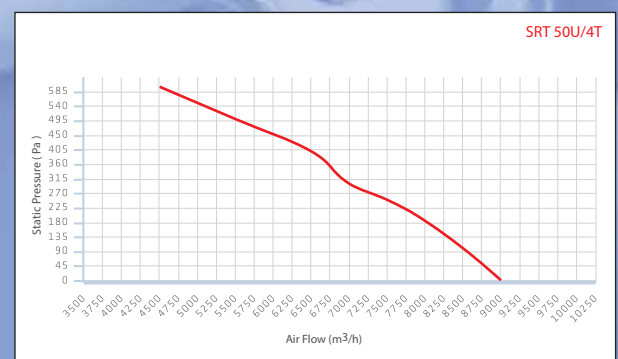
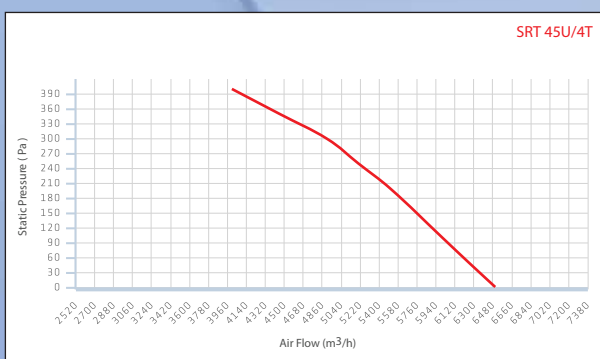
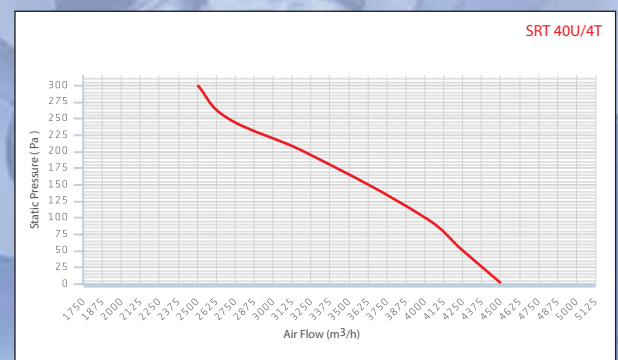
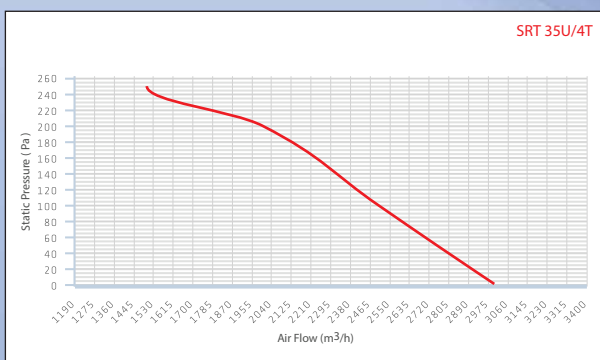

## TECHNICAL SPECIFICATIONS

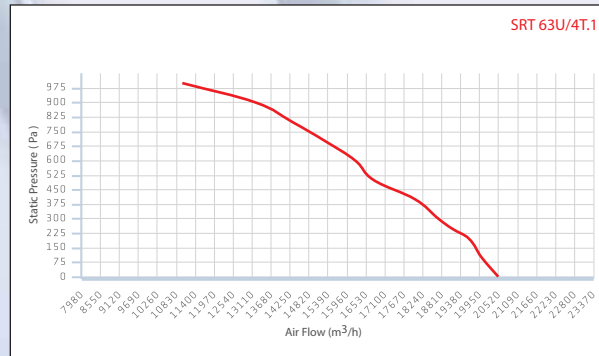
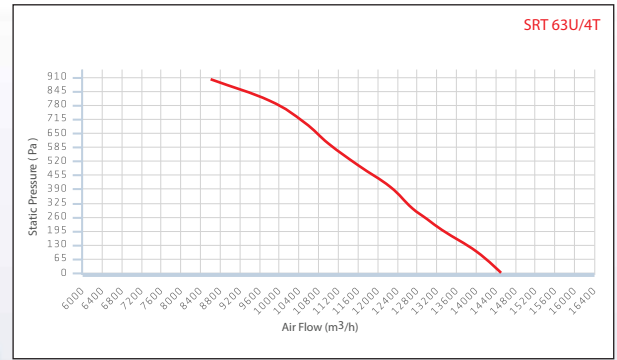
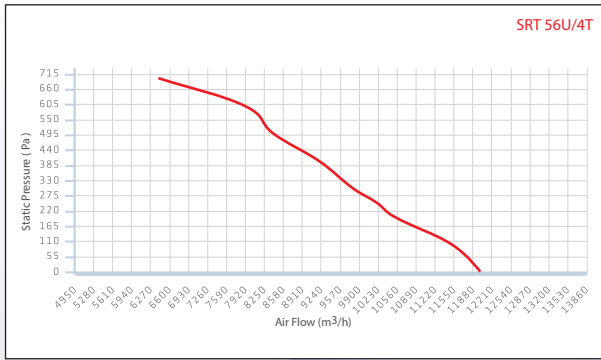

## DIMENSIONS

| MODEL        | DIMENSIONS / mm |      |     |     |
|--------------|-----------------|------|-----|-----|
|              | ØD              | □A   | □B  | □C  |
| SRT 35B/4.T  | 355             | 500  | 450 | 400 |
| SRT 40B/4.T  | 400             | 700  | 550 | 560 |
| SRT 45B/4.T  | 450             | 700  | 550 | 560 |
| SRT 50B/4.T  | 500             | 800  | 600 | 700 |
| SRT 56B/4.T  | 560             | 800  | 750 | 700 |
| SRT 63B/4.T  | 630             | 820  | 820 | 700 |
| SRT 63B/4.T1 | 630             | 1040 | 900 | 950 |

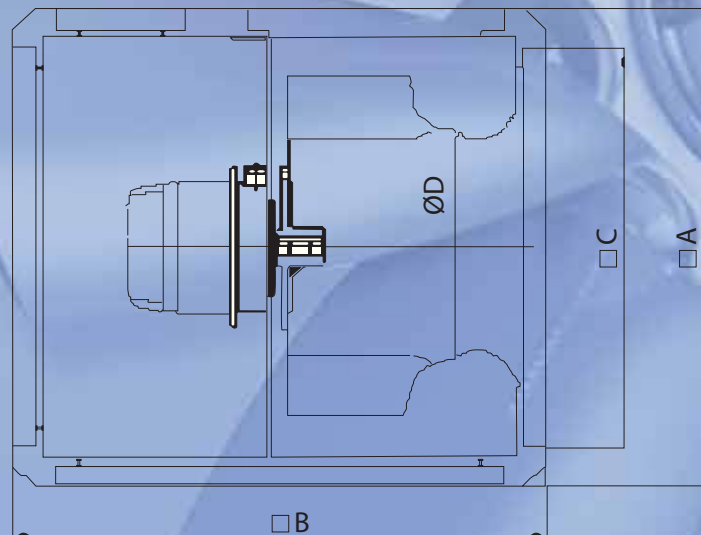

### Design parameters;

- Based on 5N per 100m<sup>2</sup> floor area, minimum total fan thrust = car park floor area x 5N/100m<sup>2</sup>
- = 1920m<sup>2</sup> x 5N/100m<sup>2</sup>
- = 96N
- Minimum thrust criteria can be achieved with 4 x JISU-CPC-50N fans on low speed (operating thrust 25N), total fan thrust= 25N x 4= 100N.
- Fans are spaced within the 30m spacing recommendation for 25N thrust.
- Final fan to wall spacing under 40m maximum spacing guide lines for 25N fan thrust. This is because the exhaust point is an area of low pressure, making it likely to enhance the fan throw distance.

### Placement of CO sensors:

Because the guidelines for positioning CO sensors in AS/NZS1668.2:2012 is based on a ducted system, we propose that the following guidelines be used as a starting point for their placement in a jet fan system.

- No part of the enclosure shall be greater than 25 metres from a sampling point. (A 50 metre diameter circle around a CO sensor can show coverage areas).
- Additional detectors shall be installed in areas where people may congregate within the car park and are not within separately ventilated areas.
- The most practical mounting position for a CO sensor within a car park is the support columns.
- CO sensors will be more effective if placed in areas where CO levels are likely to be high. Eg. Placing a CO sensor in front of a fresh air intake is not likely to be effective.

If jet fans are placed in each laneway of a car park and the recommended low speed jetfan spacings are followed, the above guidelines can be achieved by using one CO sensor per jet fan and providing additional CO sensors at congregation points. Therefore, for this car park we would suggest installing 5 (4 + 1) CO sensors for good coverage.

### Step 4 - Calculate Supply & Exhaust Rates

Section 4 of AS/NZS1668.2:2012 details requirements for ventilating car parks. In particular, sub-sections 4.4.3 and 4.4.4.2 of the standard outlines calculations of exhaust rates. In any of the two cases below, the exhaust air flow rate for a car park is taken as the greatest of the following calculations:

#### Calculation of exhaust air flow rates

Car parks with more than 40 spaces      Car parks with less than or equal to 40 spaces

a)  $2000 \times F \times T$  Litres/s (minimum air quantity for one operating car)      a) 2000 Litres/s

b)  $0.85 \times P \times (100 \times n_1 + n_1 \times d_1 + n_2 \times d_2) \times E \times T$       b)  $2.5 \times A$  Litres/s

c)  $2.5 \times A$  Litres/s (minimum air quality based on area of car park)      c)  $400 \times n_1 \times P$  Litres/s

Supply air flows should range from 75% to 90% of the exhaust air quantity.

This is based on the pressurisation of the car park, which should be 12Pa maximum.

Reference information for the calculation of exhaust air flow rates in the table above:

A = the area of the zone or level, in square metres

d1 = the average driving distance, in metres, within the zone or level under consideration for the exit of a car parked there (see Clause 4.4.4.1)

d2 = the average driving distance, in metres, within the zone or level under consideration for the exit of a car whose exit route passes through the zone or level under consideration, but excluding any part of the exit route designated as queuing areas and ventilated in accordance with Clause 4.6 (see Clause 4.4.4.1)

E = the staff exposure factor (E)

F = the staff usage factor (F)

n1 = the number of parking spaces in the zone or level under consideration (see Clause 4.3.2)

n2 = the number of parking spaces situated in other parts of the car park, having exit routes passing through the zone or level under consideration

P = the parking usage factor (P)

T = the vehicle type factor (T)

## RWD Series

### Roof Mounted Centrifugal Fans



#### USE

- Exhaust ventilation systems installed in various premises.
- Roof mounting
- For any types of roofs or vertical ventilation shafts.
- Compatible with 150 up to 315 mm round air ducts.

#### DESIGN

- Steel casing with a special polymer atmospheric resistant coating.
- Horizontal air exhaust.
- The fan is rated for continuous operation.
- A connecting plate is designed to facilitate the fan mounting to the roof surface.

#### MOTOR

- Single-phase external rotor and centrifugal impeller with backward curved blades.
- Dynamically balanced turbine.
- Equipped with ball bearings for long service life.
- Overheating protection with built-in thermal switches with automatic restart.

#### TECHNICAL SPECIFICATIONS

| MODEL   | MAX. AIR FLOW (m <sup>3</sup> /h) | WATT | SOUND (dBA) | AMPER | RPM (dk) | PRICE |
|---------|-----------------------------------|------|-------------|-------|----------|-------|
| RWD 150 | 500                               | 58   | 62          | 0,26  | 2330     | 132 € |
| RWD 200 | 1100                              | 110  | 72          | 0,52  | 2600     | 143 € |
| RWD 250 | 1500                              | 160  | 73          | 0,75  | 2500     | 160 € |
| RWD 315 | 2100                              | 190  | 74          | 0,90  | 2500     | 192 € |

#### AIR FLOW PERFORMANCE DATA

| MODEL   | AIR FLOW PERFORMANCE DATA / PA / (m <sup>3</sup> /h) |      |      |      |      |      |      |
|---------|------------------------------------------------------|------|------|------|------|------|------|
|         | 100                                                  | 200  | 250  | 300  | 350  | 400  | 500  |
| RWD150  | 430                                                  | 280  | 150  | -    | -    | -    | -    |
| RWD 200 | 900                                                  | 700  | 560  | 400  | 300  | -    | -    |
| RWD 250 | 1350                                                 | 1080 | 920  | 800  | 620  | 580  | -    |
| RWD 315 | 1970                                                 | 1800 | 1710 | 1600 | 1460 | 1300 | 1000 |

## AIR FLOW PERFORMANCE DATA

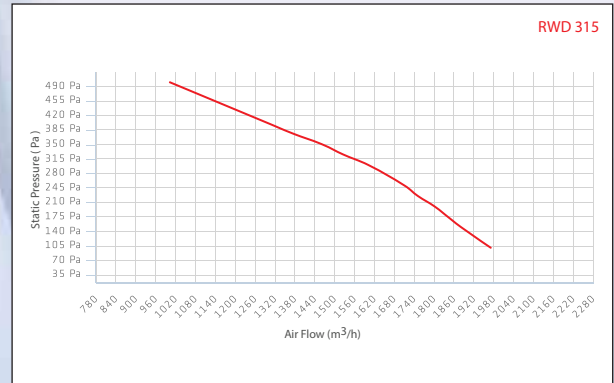
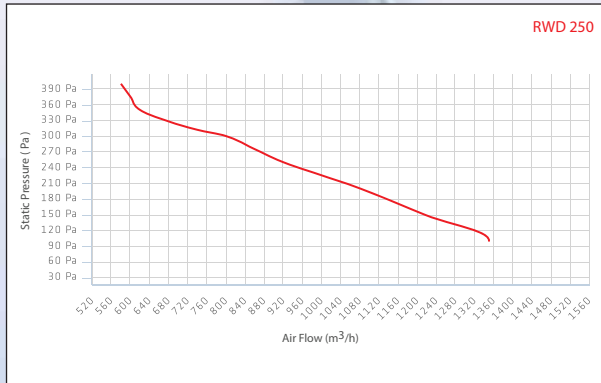
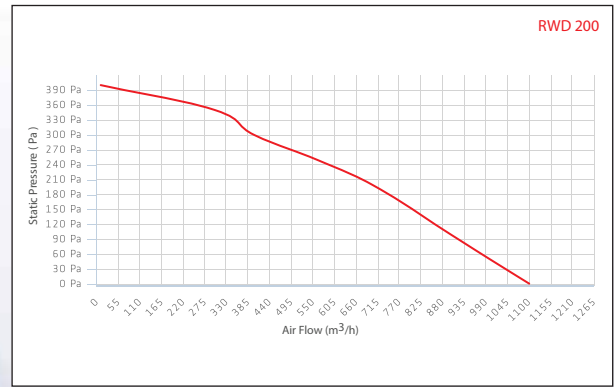
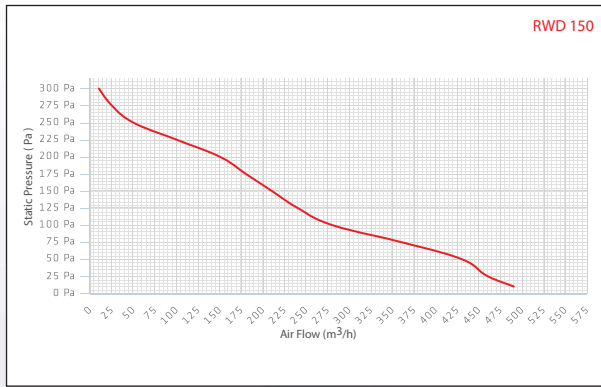

## DIMENSIONS

| MODEL   | DIMENSIONS / mm |     |     |     |     |     |     |
|---------|-----------------|-----|-----|-----|-----|-----|-----|
|         | A               | B   | C   | D   | E   | F   | G   |
| RWD 150 | 290             | 150 | 320 | 170 | 340 | 200 | 350 |
| RWD 200 | 300             | 200 | 325 | 225 | 350 | 250 | 460 |
| RWD 250 | 400             | 200 | 425 | 225 | 450 | 250 | 460 |
| RWD 315 | 400             | 300 | 425 | 325 | 450 | 350 | 600 |

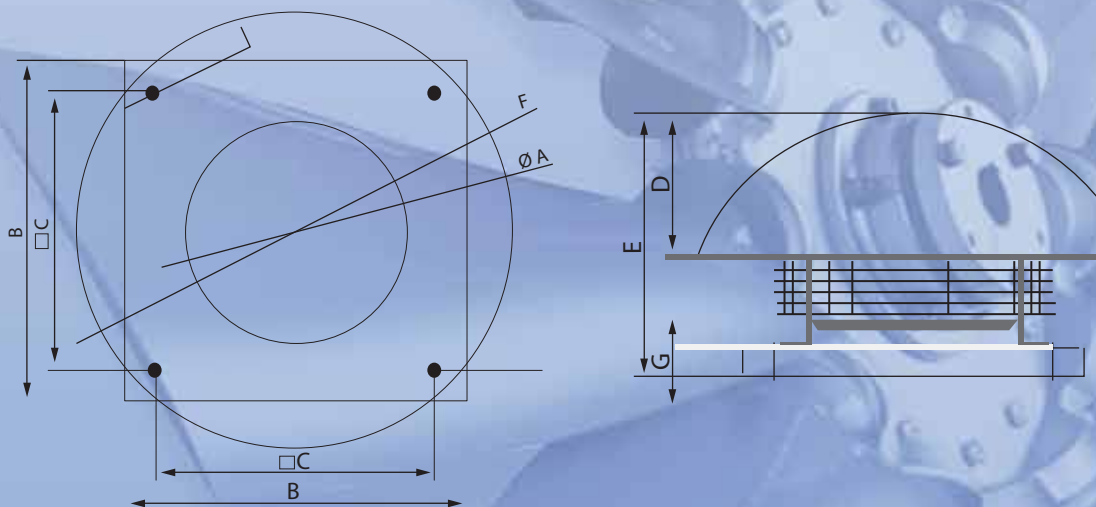

## ACCESSORIES

| MODEL    | TECHNICAL SPECIFICATIONS      |
|----------|-------------------------------|
|          | SPEED CONTROL                 |
| RS-1-400 | Electronic, Maximum 1.8 Amper |

## ARDY Series Roof Type Axial Fan

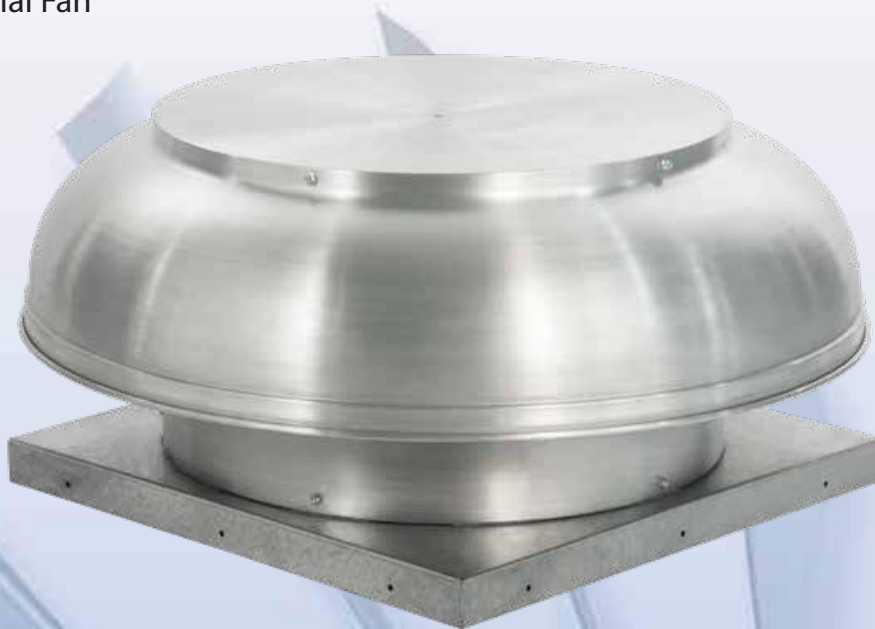

### USE

- Exhaust ventilation systems installed in various premises.
- Roof mounting.
- For any types of roof or vertical ventilation shafts.

### DESIGN

- Steel casing and impeller with a special polymer atmospheric resistant coating.
- Horizontal air exhaust.
- The fan is equipped with a terminal block for connection to power mains.
- The fan is rated for continuous operation.
- A connecting plate with an intake opening is designed to facilitate mounting to the roof surface.

### MOTOR

- Two or Four pole asynchronous motor with external rotor and axial impeller.
- Single-phase motor modification.
- Equipped with ball bearings for longer service life.
- Overheating protection by built-in thermal switches with automatic restart.

### MOUNTING

- Roof mounting directly above a ventilation shaft or air duct.
- The fan is connected to the air duct with the intake flange that is fixed to the fan base.
- The fan base has holes for fixing bolts that attach the fan to a stable level surface or a roof frame.
- Roof frame and intake flange available on separate order.
- Power is supplied through an external terminal box.

TECHNICAL SPECIFICATIONS

| MODEL     | MAX. AIR FLOW (m <sup>3</sup> /h) | WATT  | SOUND (dBA) | RPM (dk) | PRICE  |
|-----------|-----------------------------------|-------|-------------|----------|--------|
| 31U/2.T   | 4000                              | 0,55  | 85          | 2950     | 770 €  |
| 35U/2.T   | 5500                              | 1,10  | 89          | 2950     | 990 €  |
| 40U/2.T   | 8000                              | 1,50  | 92          | 2950     | 1050 € |
| 45U/2.T   | 11000                             | 3,00  | 95          | 2950     | 1110 € |
| 50U/2.T   | 14000                             | 4,00  | 96          | 2950     | 1400 € |
| 56U/2.T   | 17780                             | 5,50  | 97          | 2950     | 1575 € |
| 63U/4.T   | 12500                             | 7,50  | 85          | 1450     | 1435 € |
| 63U/4.T1  | 15500                             | 2,20  | 88          | 1450     | 1465 € |
| 63U/4.T2  | 19500                             | 3,00  | 92          | 1450     | 1500 € |
| 71U/4.T   | 24000                             | 4,00  | 91          | 1450     | 1588 € |
| 80U/4.T   | 28000                             | 5,50  | 92          | 1450     | 1766 € |
| 80U/4.T1  | 33000                             | 7,50  | 96          | 1450     | 1873 € |
| 90U/4.T   | 29000                             | 3,00  | 89          | 1450     | 1659 € |
| 90U/4.T1  | 40000                             | 7,50  | 96          | 1450     | 2033 € |
| 100U/4.T  | 43000                             | 7,50  | 93          | 1450     | 2355 € |
| 100U/4.T1 | 50000                             | 11,00 | 97          | 1450     | 2675 € |

AIR FLOW PERFORMANCE DATA

| MODEL          | AIR FLOW PERFORMANCE DATA / PA / (m <sup>3</sup> /h) |       |       |       |       |       |       |       |       |       |     |
|----------------|------------------------------------------------------|-------|-------|-------|-------|-------|-------|-------|-------|-------|-----|
|                | 1400 d/d                                             | 100   | 150   | 200   | 250   | 300   | 400   | 500   | 600   | 700   | 800 |
| ARDY 31E/2.T   | -                                                    | 4000  | 3600  | 3300  | 3000  | -     | -     | -     | -     | -     | -   |
| ARDY 35E/2.T   | -                                                    | 5500  | 5235  | 5000  | 4750  | 4100  | -     | -     | -     | -     | -   |
| ARDY 40E/2.T   | -                                                    | -     | 8000  | 7600  | 7300  | 6550  | 5710  | 3510  | -     | -     | -   |
| ARDY 45E/2.T   | -                                                    | -     | -     | 11000 | 10400 | 9700  | 8750  | 7300  | -     | -     | -   |
| ARDY 50E/2.T   | -                                                    | -     | -     | 14000 | 13600 | 13000 | 11900 | 10550 | 8900  | -     | -   |
| ARDY 56E/2.T   | -                                                    | -     | -     | -     | 17780 | 16770 | 15680 | 14400 | 12700 | 10500 | -   |
| ARDY 63U/4.T   | 12500                                                | 12000 | 11500 | 9500  | -     | -     | -     | -     | -     | -     | -   |
| ARDY 63U/4.T1  | 15500                                                | 15000 | 14500 | 13000 | -     | -     | -     | -     | -     | -     | -   |
| ARDY 63U/4.T2  | 19500                                                | 18800 | 18000 | 16000 | -     | -     | -     | -     | -     | -     | -   |
| ARDY 71E/4.T   | -                                                    | -     | 24000 | 19000 | 16000 | -     | -     | -     | -     | -     | -   |
| ARDY 80E/4.T   | 28000                                                | 28000 | 26500 | 25000 | 20000 | 13000 | -     | -     | -     | -     | -   |
| ARDY 80E/4.T1  | -                                                    | -     | 33000 | 28000 | 25000 | 20000 | -     | -     | -     | -     | -   |
| ARDY 90E/4.T   | 29000                                                | 29000 | 26000 | 23500 | 20000 | 16000 | -     | -     | -     | -     | -   |
| ARDY 90E/4.T1  | -                                                    | -     | 40000 | 37000 | 34000 | 27500 | -     | -     | -     | -     | -   |
| ARDY 100E/4.T  | 43000                                                | 43000 | 41000 | 39000 | 37500 | 32000 | 25000 | 20000 | -     | -     | -   |
| ARDY 100E/4.T1 | -                                                    | -     | 50000 | 48000 | 46500 | 42000 | 35600 | 25000 | -     | -     | -   |

## DIMENSIONS

| MODEL     | DIMENSIONS/ mm |      |      |      |      |    |      |        |        |
|-----------|----------------|------|------|------|------|----|------|--------|--------|
|           | A              | C    | E    | B    | D    | C  | L    | n°4xØF | n°HxØl |
| ARDY 31E  | 315            | 565  | 500  | 400  | 600  | 30 | 356  | 4 x 8  | 356    |
| ARDY 35E  | 350            | 565  | 700  | 600  | 600  | 30 | 595  | 4 x 8  | 395    |
| ARDY 40E  | 400            | 720  | 700  | 600  | 700  | 30 | 450  | 4 x 8  | 438    |
| ARDY 45E  | 450            | 720  | 700  | 600  | 700  | 30 | 500  | 4 x 12 | 487    |
| ARDY 50E  | 500            | 720  | 800  | 700  | 800  | 30 | 560  | 4 x 12 | 541    |
| ARDY 56E  | 560            | 920  | 1000 | 700  | 800  | 40 | 620  | 4 x 12 | 605    |
| ARDY 63E  | 630            | 920  | 1000 | 900  | 800  | 40 | 690  | 4 x 12 | 674    |
| ARDY 71E  | 710            | 920  | 1000 | 900  | 900  | 40 | 770  | 4 x 14 | 751    |
| ARDY 80E  | 800            | 1170 | 1250 | 1100 | 900  | 40 | 860  | 4 x 14 | 837    |
| ARDY 90E  | 900            | 1170 | 1250 | 1100 | 900  | 40 | 970  | 4 x 14 | 934    |
| ARDY 100E | 1000           | 1400 | 1400 | 1200 | 1000 | 50 | 1070 | 4 x 14 | 1043   |

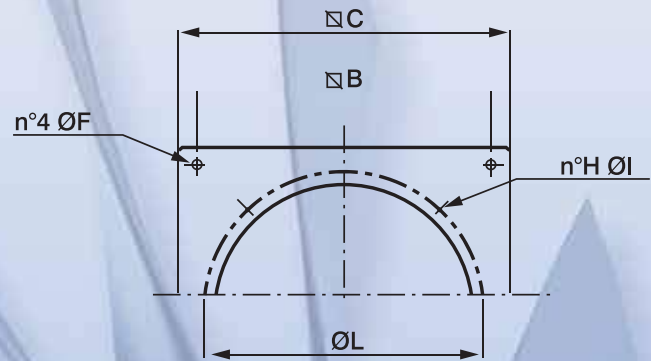
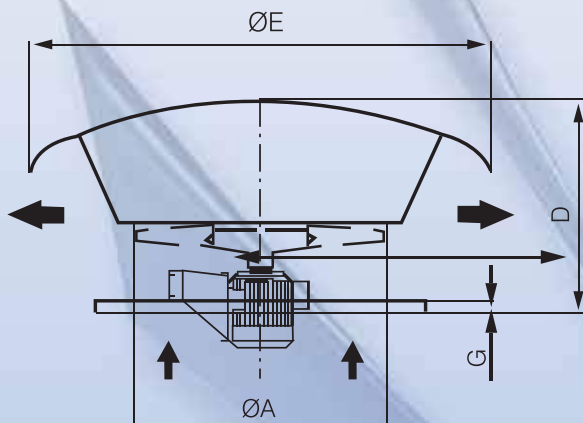

## ACCESSORIES





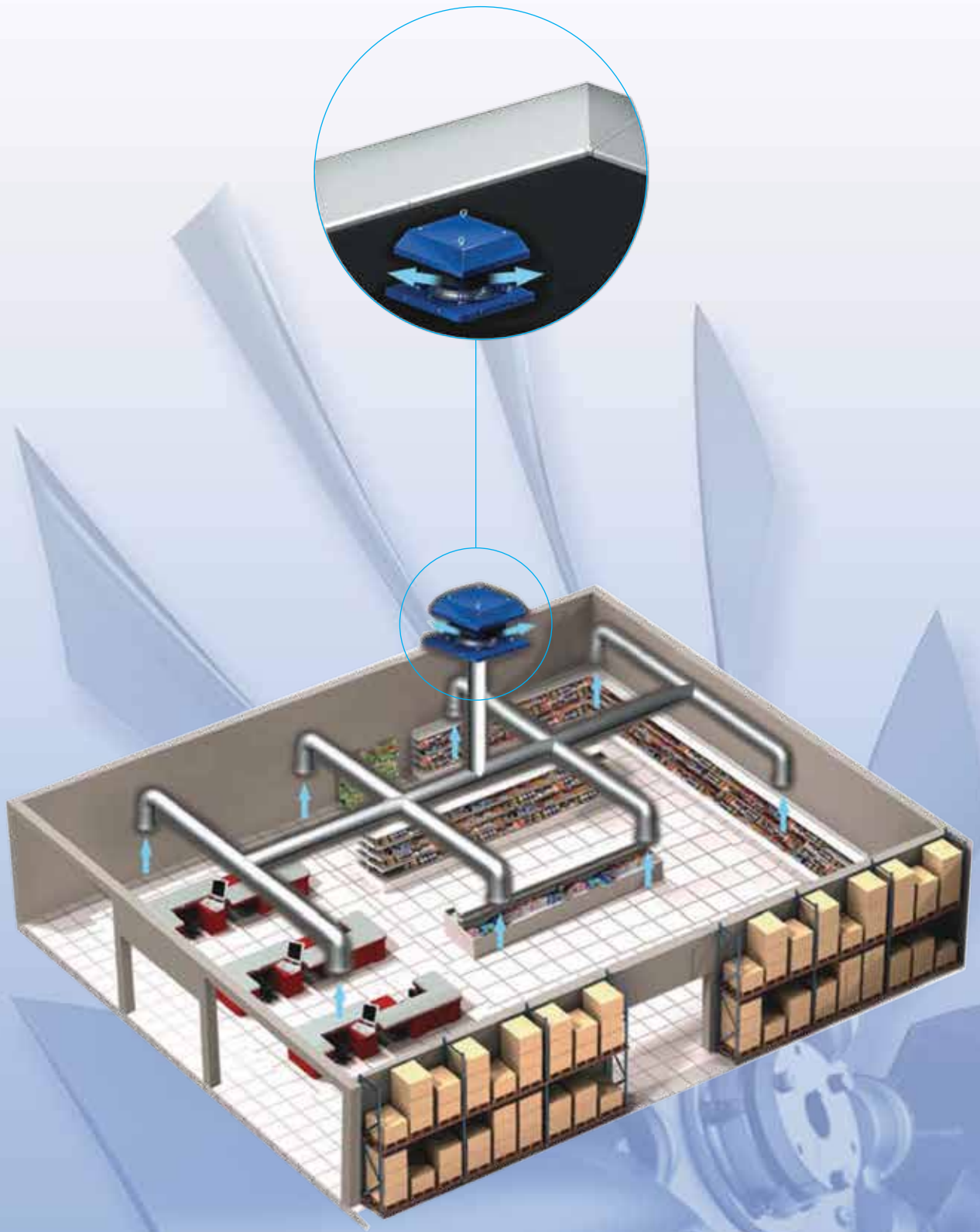

## RDY Series Roof Type Centrifugal Fan



### USE

- Exhaust ventilation systems installed in various premises.
- Roof mounting.
- For any types of roof or vertical ventilation shafts.

### DESIGN

- Steel casing and impeller with a special polymer atmospheric resistant coating.
- Horizontal air exhaust.
- The fan is equipped with a terminal block for connection to power mains.
- The fan is rated for continuous operation.
- Impeller with a protecting insect screen.
- The upper cover is equipped with two eye bolts for easy fan lifting on the roof with hoisting mechanism.
- A connecting plate with an intake opening is designed to facilitate mounting to the roof surface.

### MOTOR

- Two or Four pole asynchronous motor with external rotor and centrifugal impeller with backward curved blades.
- Three-phase motor modification.
- Dynamically balanced turbine.
- Equipped with ball bearings for longer service life.
- Overheating protection by built-in thermal switches with leaded outside terminals for connection to external protecting controls.
- The thermal switch terminal leads are designed for connection to respective circuit of the overload relay or respective terminals of the autotransformer or thyristor speed controller.

### MOUNTING

- Roof mounting directly above a ventilation shaft or air duct.
- The fan is connected to the air duct with the intake flange that is fixed to the fan base.
- The fan base has holes for fixing bolts that attach the fan to a stable level surface or a roof frame.
- Roof frame and intake flange available on separate order.
- Power is supplied through an external terminal box.

TECHNICAL SPECIFICATIONS

| MODEL      | MAX. AIR FLOW (m <sup>3</sup> /h) | WATT  | PRESSURE (Pa) | DEVİR (dk) | VOLTAGE (V) | PRICE  |
|------------|-----------------------------------|-------|---------------|------------|-------------|--------|
| RDY 32A-4T | 3000                              | 0,55  | 400           | 1450       | 400         | 483 €  |
| RDY 40A-4T | 4000                              | 0,75  | 500           | 1450       | 400         | 583 €  |
| RDY 40B-4T | 5000                              | 0,75  | 550           | 1450       | 400         | 633 €  |
| RDY 40C-4T | 6000                              | 1,10  | 600           | 1450       | 400         | 716 €  |
| RDY 45A-4T | 7000                              | 1,10  | 650           | 1450       | 400         | 800 €  |
| RDY 45B-4T | 8000                              | 1,50  | 750           | 1450       | 400         | 900 €  |
| RDY 45C-4T | 9000                              | 2,20  | 800           | 1450       | 400         | 970 €  |
| RDY 50A-4T | 10000                             | 2,20  | 850           | 1450       | 400         | 1070 € |
| RDY 50B-4T | 12000                             | 3,00  | 950           | 1450       | 400         | 1250 € |
| RDY 55A-4T | 14000                             | 4,00  | 1050          | 1450       | 400         | 1670 € |
| RDY 55B-4T | 16000                             | 4,00  | 1100          | 1450       | 400         | 1800 € |
| RDY 63A-4T | 18000                             | 5,50  | 1200          | 1450       | 400         | 2000 € |
| RDY 63B-4T | 20000                             | 7,50  | 1300          | 1450       | 400         | 2350 € |
| RDY 63C-4T | 22000                             | 7,50  | 1400          | 1450       | 400         | 2500 € |
| RDY 70A-4T | 26000                             | 11,00 | 1600          | 1450       | 400         | 2680 € |
| RDY 70B-4T | 30000                             | 15,00 | 1800          | 1450       | 400         | 3200 € |
| RDY 80A-4T | 40000                             | 18,50 | 2000          | 1450       | 400         | 4180 € |
| RDY 80B-4T | 50000                             | 22,00 | 2250          | 1450       | 400         | 4680 € |
| RDY 70B-6T | 20000                             | 5,50  | 450           | 1000       | 400         | 3350 € |
| RDY 80C-6T | 30000                             | 7,50  | 500           | 1000       | 400         | 3833 € |

AIR FLOW PERFORMANCE DATA

| MODEL      | AIR FLOW PERFORMANCE DATA / PA / (m <sup>3</sup> /h) |      |       |       |       |       |       |       |       |       |       |       |      |
|------------|------------------------------------------------------|------|-------|-------|-------|-------|-------|-------|-------|-------|-------|-------|------|
|            | 1400 d/d                                             | 100  | 200   | 300   | 400   | 500   | 600   | 700   | 800   | 900   | 1000  | 1100  | 1200 |
| RDY 32A-4T | 3000                                                 | 2500 | 1700  | -     | -     | -     | -     | -     | -     | -     | -     | -     | -    |
| RDY 40A-4T | 4000                                                 | 3200 | 2700  | 1500  | -     | -     | -     | -     | -     | -     | -     | -     | -    |
| RDY 40B-4T | 5000                                                 | 4300 | 3800  | 2200  | 1800  | -     | -     | -     | -     | -     | -     | -     | -    |
| RDY 40C-4T | 6000                                                 | 5400 | 4600  | 3000  | 2400  | -     | -     | -     | -     | -     | -     | -     | -    |
| RDY 45A-4T | 7000                                                 | 6500 | 6000  | 5400  | 4200  | 2400  | -     | -     | -     | -     | -     | -     | -    |
| RDY 45B-4T | -                                                    | -    | 8000  | 6700  | 5700  | 4200  | 2700  | -     | -     | -     | -     | -     | -    |
| RDY 45C-4T | -                                                    | -    | 9000  | 8000  | 7300  | 5700  | 5800  | 3000  | -     | -     | -     | -     | -    |
| RDY 50A-4T | -                                                    | -    | 10000 | 9000  | 8400  | 7300  | 6000  | 3360  | -     | -     | -     | -     | -    |
| RDY 50B-4T | -                                                    | -    | 12000 | 11000 | 9600  | 8400  | 7500  | 6000  | 4000  | -     | -     | -     | -    |
| RDY 55A-4T | -                                                    | -    | 14000 | 13700 | 13000 | 12000 | 11500 | 11000 | 8400  | 5400  | -     | -     | -    |
| RDY 55B-4T | -                                                    | -    | -     | -     | 16000 | 14000 | 13000 | 12000 | 9800  | 8400  | 6000  | -     | -    |
| RDY 63A-4T | -                                                    | -    | -     | -     | 18000 | 17300 | 17000 | 16800 | 15600 | 15000 | 13000 | 10000 | -    |
| RDY 63B-4T | -                                                    | -    | -     | -     | -     | 20000 | 18000 | 19000 | 16800 | 16000 | 14000 | 12000 | -    |
| RDY 63C-4T | -                                                    | -    | -     | -     | -     | -     | 22000 | 24500 | 19000 | 17000 | 14000 | 11500 | -    |
| RDY 70A-4T | -                                                    | -    | -     | -     | -     | -     | 26000 | 31000 | 24500 | 24000 | 23000 | 22000 | -    |
| RDY 70B-4T | -                                                    | -    | -     | -     | -     | -     | 33000 | 40000 | 31000 | 30000 | 27000 | 25000 | -    |
| RDY 80A-4T | -                                                    | -    | -     | -     | -     | -     | -     | 50000 | 40000 | 39000 | 38000 | 37000 | -    |
| RDY 80B-4T | -                                                    | -    | -     | -     | -     | -     | -     | -     | 50000 | 47000 | 45000 | 43000 | -    |

AIR FLOW PERFORMANCE DATA

| MODEL      | AIR FLOW PERFORMANCE DATA / PA / (m <sup>3</sup> /h) |       |       |       |       |       |       |       |       |       |       |      |      |
|------------|------------------------------------------------------|-------|-------|-------|-------|-------|-------|-------|-------|-------|-------|------|------|
|            | 1400 d/d                                             | 1300  | 1400  | 1500  | 1600  | 1700  | 1800  | 1900  | 2000  | 2100  | 2200  | 2300 | 2400 |
| RDY 32A-4T | -                                                    | -     | -     | -     | -     | -     | -     | -     | -     | -     | -     | -    | -    |
| RDY 40A-4T | -                                                    | -     | -     | -     | -     | -     | -     | -     | -     | -     | -     | -    | -    |
| RDY 40B-4T | -                                                    | -     | -     | -     | -     | -     | -     | -     | -     | -     | -     | -    | -    |
| RDY 40C-4T | -                                                    | -     | -     | -     | -     | -     | -     | -     | -     | -     | -     | -    | -    |
| RDY 45A-4T | -                                                    | -     | -     | -     | -     | -     | -     | -     | -     | -     | -     | -    | -    |
| RDY 45B-4T | -                                                    | -     | -     | -     | -     | -     | -     | -     | -     | -     | -     | -    | -    |
| RDY 45C-4T | -                                                    | -     | -     | -     | -     | -     | -     | -     | -     | -     | -     | -    | -    |
| RDY 50A-4T | -                                                    | -     | -     | -     | -     | -     | -     | -     | -     | -     | -     | -    | -    |
| RDY 50B-4T | -                                                    | -     | -     | -     | -     | -     | -     | -     | -     | -     | -     | -    | -    |
| RDY 55A-4T | -                                                    | -     | -     | -     | -     | -     | -     | -     | -     | -     | -     | -    | -    |
| RDY 55B-4T | -                                                    | -     | -     | -     | -     | -     | -     | -     | -     | -     | -     | -    | -    |
| RDY 63A-4T | 8400                                                 | -     | -     | -     | -     | -     | -     | -     | -     | -     | -     | -    | -    |
| RDY 63B-4T | 10000                                                | 9000  | -     | -     | -     | -     | -     | -     | -     | -     | -     | -    | -    |
| RDY 63C-4T | 9000                                                 | -     | -     | -     | -     | -     | -     | -     | -     | -     | -     | -    | -    |
| RDY 70A-4T | 20000                                                | 17000 | 14000 | -     | -     | -     | -     | -     | -     | -     | -     | -    | -    |
| RDY 70B-4T | 24000                                                | 20000 | 19700 | 19000 | 15000 | 11000 | -     | -     | -     | -     | -     | -    | -    |
| RDY 80A-4T | 36000                                                | 35000 | 34000 | 32000 | 30000 | 29000 | 27000 | 24000 | 18000 | -     | -     | -    | -    |
| RDY 80B-4T | 40000                                                | 38000 | 37000 | 36000 | 34000 | 32000 | 30000 | 26000 | 24000 | 22000 | 16000 | -    | -    |

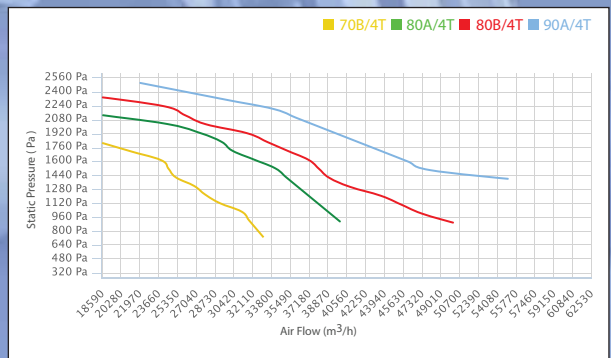
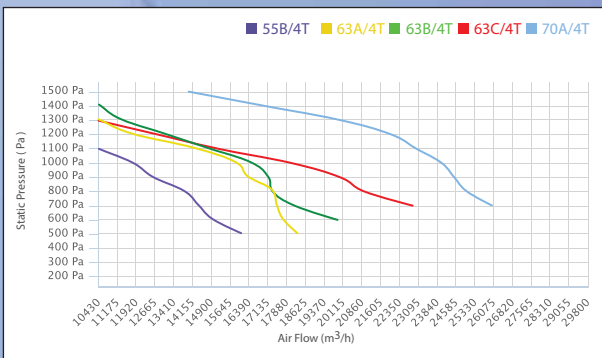
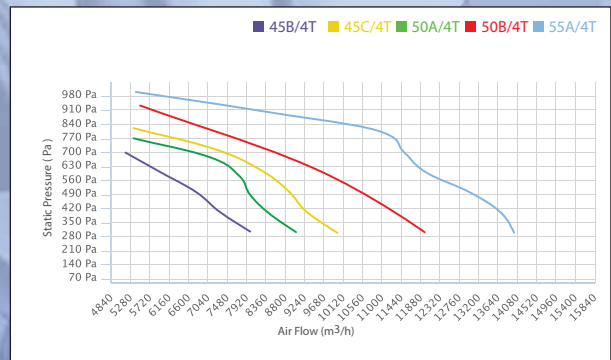
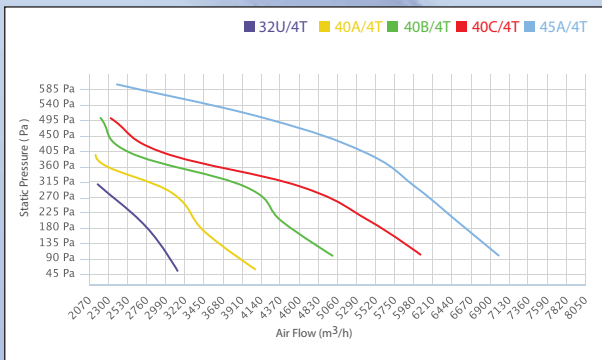

## DIMENSIONS

| MODEL  | DIMENSIONS / mm |      |      |     |
|--------|-----------------|------|------|-----|
|        | A               | B    | C    | ØD  |
| RDY 32 | 550             | 480  | 480  | 250 |
| RDY 40 | 685             | 600  | 600  | 320 |
| RDY 45 | 685             | 600  | 600  | 350 |
| RDY 50 | 850             | 770  | 770  | 400 |
| RDY 55 | 850             | 770  | 770  | 450 |
| RDY 63 | 900             | 1000 | 1000 | 500 |
| RDY 70 | 1155            | 1000 | 1000 | 650 |
| RDY 80 | 1280            | 1100 | 1100 | 650 |

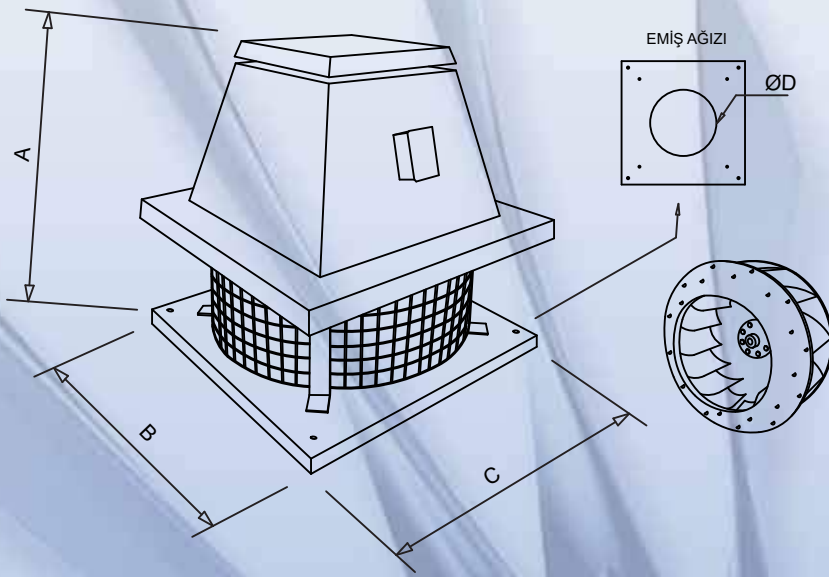

## ACCESSORIES



### RDV Series Roof Type Centrifugal Fan



#### USE

- Exhaust ventilation systems installed in various premises.
- Roof mounting.
- For any types of roof or vertical ventilation shafts.

#### DESIGN

- Steel casing and impeller with a special polymer atmospheric resistant coating.
- Vertical air exhaust.
- The fan is equipped with a terminal block for connection to power mains.
- The fan is rated for continuous operation.
- Impeller with a protecting insect screen.
- The upper cover is equipped with two eye bolts for easy fan lifting on the roof with hoisting mechanism.
- A connecting plate with an intake opening is designed to facilitate mounting to the roof surface.

#### MOTOR

- Two or Four pole asynchronous motor with external rotor and centrifugal impeller with backward curved blades.
- Three-phase motor modification.
- Dynamically balanced turbine.
- Equipped with ball bearings for longer service life.
- Overheating protection by built-in thermal switches with leaded outside terminals for connection to external protecting controls.
- The thermal switch terminal leads are designed for connection to respective circuit of the overload relay or respective terminals of the autotransformer or thyristor speed controller.

#### MOUNTING

- Roof mounting directly above a ventilation shaft or air duct.
- The fan is connected to the air duct with the intake flange that is fixed to the fan base.
- The fan base has holes for fixing bolts that attach the fan to a stable level surface or a roof frame.
- Roof frame and intake flange available on separate order.
- Power is supplied through an external terminal box.

TECHNICAL SPECIFICATIONS

| MODEL      | MAX. AIR FLOW (m <sup>3</sup> /h) | WATT  | PRESSURE (Pa) | RPM (dk) | VOLTAGE (V) | PRICE  |
|------------|-----------------------------------|-------|---------------|----------|-------------|--------|
| RDV 32A-4T | 3000                              | 0,55  | 400           | 1450     | 400         | 683 €  |
| RDV 40A-4T | 4000                              | 0,75  | 500           | 1450     | 400         | 900 €  |
| RDV 40B-4T | 5000                              | 0,75  | 550           | 1450     | 400         | 1000 € |
| RDV 40C-4T | 6000                              | 1,10  | 600           | 1450     | 400         | 1085 € |
| RDV 45A-4T | 7000                              | 1,10  | 650           | 1450     | 400         | 1270 € |
| RDV 45B-4T | 8000                              | 1,50  | 750           | 1450     | 400         | 1345 € |
| RDV 45C-4T | 9000                              | 2,20  | 800           | 1450     | 400         | 1470 € |
| RDV 50A-4T | 10000                             | 2,20  | 850           | 1450     | 400         | 1600 € |
| RDV 50B-4T | 12000                             | 3,00  | 950           | 1450     | 400         | 1670 € |
| RDV 55A-4T | 14000                             | 4,00  | 1050          | 1450     | 400         | 2170 € |
| RDV 55B-4T | 16000                             | 4,00  | 1100          | 1450     | 400         | 2400 € |
| RDV 63A-4T | 18000                             | 5,50  | 1200          | 1450     | 400         | 2840 € |
| RDV 63B-4T | 20000                             | 7,50  | 1300          | 1450     | 400         | 3340 € |
| RDV 63C-4T | 22000                             | 7,50  | 1400          | 1450     | 400         | 3500 € |
| RDV 70A-4T | 26000                             | 11,00 | 1600          | 1450     | 400         | 3850 € |
| RDV 70B-4T | 30000                             | 15,00 | 1800          | 1450     | 400         | 4500 € |
| RDV 80A-4T | 40000                             | 18,50 | 2000          | 1450     | 400         | 5500 € |
| RDV 80B-4T | 50000                             | 22,00 | 2250          | 1450     | 400         | 6000 € |
| RDV 70B-6T | 20000                             | 5,50  | 450           | 1000     | 400         | 4000 € |
| RDV 80C-6T | 30000                             | 7,50  | 500           | 1000     | 400         | 3680 € |

AIR FLOW PERFORMANCE DATA

| MODEL      | AIR FLOW PERFORMANCE DATA / PA / (m <sup>3</sup> /h) |      |       |       |       |       |       |       |       |       |       |       |      |
|------------|------------------------------------------------------|------|-------|-------|-------|-------|-------|-------|-------|-------|-------|-------|------|
|            | 1400 d/d                                             | 100  | 200   | 300   | 400   | 500   | 600   | 700   | 800   | 900   | 1000  | 1100  | 1200 |
| RDV 32A-4T | 3000                                                 | 2500 | 1700  | -     | -     | -     | -     | -     | -     | -     | -     | -     | -    |
| RDV 40A-4T | 4000                                                 | 3200 | 2700  | 1500  | -     | -     | -     | -     | -     | -     | -     | -     | -    |
| RDV 40B-4T | 5000                                                 | 4300 | 3800  | 2200  | 1800  | -     | -     | -     | -     | -     | -     | -     | -    |
| RDV 40C-4T | 6000                                                 | 5400 | 4600  | 3000  | 2400  | -     | -     | -     | -     | -     | -     | -     | -    |
| RDV 45A-4T | 7000                                                 | 6500 | 6000  | 5400  | 4200  | 2400  | -     | -     | -     | -     | -     | -     | -    |
| RDV 45B-4T | -                                                    | -    | 8000  | 6700  | 5700  | 4200  | 2700  | -     | -     | -     | -     | -     | -    |
| RDV 45C-4T | -                                                    | -    | 9000  | 8000  | 7300  | 5700  | 5800  | 3000  | -     | -     | -     | -     | -    |
| RDV 50A-4T | -                                                    | -    | 10000 | 9000  | 8400  | 7300  | 6000  | 3360  | -     | -     | -     | -     | -    |
| RDV 50B-4T | -                                                    | -    | 12000 | 11000 | 9600  | 8400  | 7500  | 6000  | 4000  | -     | -     | -     | -    |
| RDV 55A-4T | -                                                    | -    | 14000 | 13700 | 13000 | 12000 | 11500 | 11000 | 8400  | 5400  | -     | -     | -    |
| RDV 55B-4T | -                                                    | -    | -     | -     | 16000 | 14000 | 13000 | 12000 | 9800  | 8400  | 6000  | -     | -    |
| RDV 63A-4T | -                                                    | -    | -     | -     | 18000 | 17300 | 17000 | 16800 | 15600 | 15000 | 13000 | 10000 | -    |
| RDV 63B-4T | -                                                    | -    | -     | -     | -     | 20000 | 18000 | 19000 | 16800 | 16000 | 14000 | 12000 | -    |
| RDV 63C-4T | -                                                    | -    | -     | -     | -     | -     | 22000 | 24500 | 19000 | 17000 | 14000 | 11500 | -    |
| RDV 70A-4T | -                                                    | -    | -     | -     | -     | -     | 26000 | 31000 | 24500 | 24000 | 23000 | 22000 | -    |
| RDV 70B-4T | -                                                    | -    | -     | -     | -     | -     | 33000 | 40000 | 31000 | 30000 | 27000 | 25000 | -    |
| RDV 80A-4T | -                                                    | -    | -     | -     | -     | -     | -     | 50000 | 40000 | 39000 | 38000 | 37000 | -    |
| RDV 80B-4T | -                                                    | -    | -     | -     | -     | -     | -     | -     | 50000 | 47000 | 45000 | 43000 | -    |

AIR FLOW PERFORMANCE DATA

| MODEL      | AIR FLOW PERFORMANCE DATA / PA / (m <sup>3</sup> /h) |       |       |       |       |       |       |       |       |       |       |      |      |
|------------|------------------------------------------------------|-------|-------|-------|-------|-------|-------|-------|-------|-------|-------|------|------|
|            | 1400 d/d                                             | 1300  | 1400  | 1500  | 1600  | 1700  | 1800  | 1900  | 2000  | 2100  | 2200  | 2300 | 2400 |
| RDV 32A-4T | -                                                    | -     | -     | -     | -     | -     | -     | -     | -     | -     | -     | -    | -    |
| RDV 40A-4T | -                                                    | -     | -     | -     | -     | -     | -     | -     | -     | -     | -     | -    | -    |
| RDV 40B-4T | -                                                    | -     | -     | -     | -     | -     | -     | -     | -     | -     | -     | -    | -    |
| RDV 40C-4T | -                                                    | -     | -     | -     | -     | -     | -     | -     | -     | -     | -     | -    | -    |
| RDV 45A-4T | -                                                    | -     | -     | -     | -     | -     | -     | -     | -     | -     | -     | -    | -    |
| RDV 45B-4T | -                                                    | -     | -     | -     | -     | -     | -     | -     | -     | -     | -     | -    | -    |
| RDV 45C-4T | -                                                    | -     | -     | -     | -     | -     | -     | -     | -     | -     | -     | -    | -    |
| RDV 50A-4T | -                                                    | -     | -     | -     | -     | -     | -     | -     | -     | -     | -     | -    | -    |
| RDV 50B-4T | -                                                    | -     | -     | -     | -     | -     | -     | -     | -     | -     | -     | -    | -    |
| RDV 55A-4T | -                                                    | -     | -     | -     | -     | -     | -     | -     | -     | -     | -     | -    | -    |
| RDV 55B-4T | -                                                    | -     | -     | -     | -     | -     | -     | -     | -     | -     | -     | -    | -    |
| RDV 63A-4T | 8400                                                 | -     | -     | -     | -     | -     | -     | -     | -     | -     | -     | -    | -    |
| RDV 63B-4T | 10000                                                | 9000  | -     | -     | -     | -     | -     | -     | -     | -     | -     | -    | -    |
| RDV 63C-4T | 9000                                                 | -     | -     | -     | -     | -     | -     | -     | -     | -     | -     | -    | -    |
| RDV 70A-4T | 20000                                                | 17000 | 14000 | -     | -     | -     | -     | -     | -     | -     | -     | -    | -    |
| RDV 70B-4T | 24000                                                | 20000 | 19700 | 19000 | 15000 | 11000 | -     | -     | -     | -     | -     | -    | -    |
| RDV 80A-4T | 36000                                                | 35000 | 34000 | 32000 | 30000 | 29000 | 27000 | 24000 | 18000 | -     | -     | -    | -    |
| RDV 80B-4T | 40000                                                | 38000 | 37000 | 36000 | 34000 | 32000 | 30000 | 26000 | 24000 | 22000 | 16000 | -    | -    |

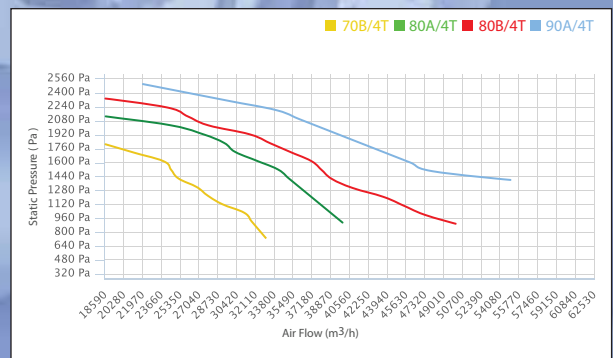
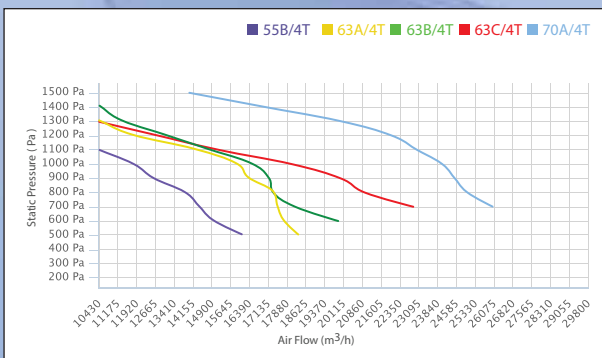
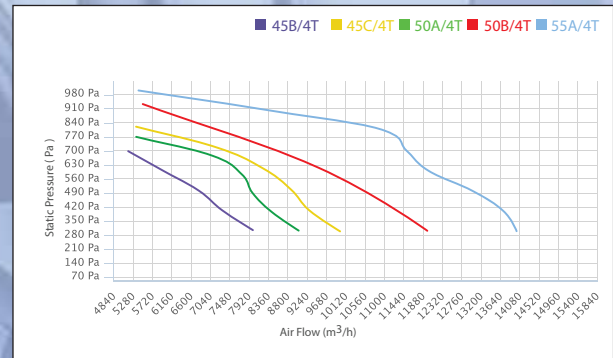
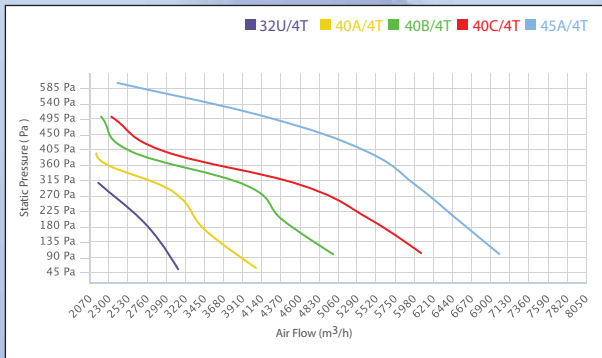



## DIMENSIONS

| MODEL  | DIMENSIONS / mm |      |      |     |
|--------|-----------------|------|------|-----|
|        | A               | B    | C    | ØD  |
| RDV 32 | 600             | 600  | 525  | 250 |
| RDV 40 | 700             | 700  | 600  | 320 |
| RDV 45 | 700             | 700  | 605  | 350 |
| RDV 50 | 790             | 790  | 705  | 400 |
| RDV 55 | 870             | 870  | 770  | 450 |
| RDV 63 | 1000            | 1000 | 900  | 500 |
| RDV 70 | 1100            | 1100 | 950  | 650 |
| RDV 80 | 1230            | 1230 | 1260 | 745 |

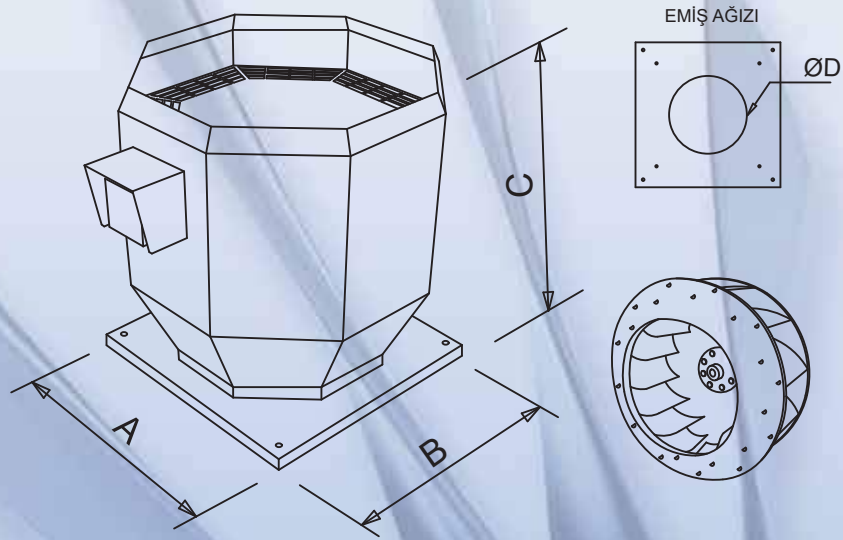

## ACCESSORIES



## ARDY - EX Series

Roof Type Axial  
Explosion-Proof Fan



Extremely robust. multi-purpose roof-mounted extractor fans for large air flow with ATEX Certification and CEE ExII2G EX e explosion-proof. CEE ExII2G Ex d. Ex tc or Ex tb non-sparking motor for working in explosive atmospheres containing dust or gas.

### FAN

- Painted galvanised sheet steel support base.
- Cast aluminium orientable rotors.
- Anti-contact protective grille pursuant to standard UNE-EN ISO 12499.
- Painted galvanised sheet steel rain cap. with natural air outlet.

### MOTOR

- ATEX- Certified. Ex e explosion proof. Ex d. Ex tc or Ex tb non-sparking class F motors with ball bearings.
- Single-phase 230V-50Hz and three-phase 230/400V-50Hz and 400/690V-50Hz (powers higher than 4 Kw).
- Operating temperature -20°C + 55°C.

### FINISH

- ATEX corrosion-proof with nonferric paint finish of polyester resin polymerised at 190°C previously degreased with phosphate-free nanotechnological treatment.

### ON REQUEST

- Made entirely of stainless steel.
- Made of hot-dip galvanised steel
- Motors with built-in PTC.
- Special windings for different voltages and frequencies.
- ATEX construction for different categories.
- Extractor fans with 2-speed motors.
- Single-phase Ex-d non-sparking motors.

## TECHNICAL SPECIFICATIONS

| MODEL         | MAX. AIR FLOW (m <sup>3</sup> /h) | WATT | SOUND (dBA) | AMPER | RPM (dk) | PRICE  |
|---------------|-----------------------------------|------|-------------|-------|----------|--------|
| ARDY 31U/4.Ex | 2200                              | 0.10 | 71          | 0.22  | 1450     | 1177 € |
| ARDY 35U/4.Ex | 2800                              | 0.14 | 73          | 0.28  | 1450     | 1242 € |
| ARDY 40U/4.Ex | 4400                              | 0.23 | 75          | 0.46  | 1450     | 1305 € |
| ARDY 45U/4.Ex | 6000                              | 0.38 | 76          | 0.80  | 1450     | 1562 € |
| ARDY 50U/4.Ex | 7900                              | 0.43 | 77          | 1.07  | 1450     | 1875 € |
| ARDY 56U/6.Ex | 8500                              | 0.37 | 73          | 1.00  | 960      | 2355 € |
| ARDY 63U/6.Ex | 11800                             | 0.55 | 75          | 1.30  | 960      | 2675 € |

## AIR FLOW PERFORMANCE DATA

| MODEL         | AIR FLOW PERFORMANCE DATA / PA / (m <sup>3</sup> /h) |       |       |      |      |      |      |      |      |      |      |
|---------------|------------------------------------------------------|-------|-------|------|------|------|------|------|------|------|------|
|               | 0                                                    | 10    | 20    | 30   | 40   | 50   | 60   | 70   | 80   | 90   | 100  |
| ARDY 31U/4.Ex | 2200                                                 | 2100  | 2000  | 1750 | 1500 | -    | -    | -    | -    | -    | -    |
| ARDY 35U/4.Ex | 2800                                                 | 2600  | 2400  | 2200 | 2000 | -    | -    | -    | -    | -    | -    |
| ARDY 40U/4.Ex | 4400                                                 | 4200  | 4000  | 3750 | 3500 | 3250 | 2800 | -    | -    | -    | -    |
| ARDY 45U/4.Ex | 6000                                                 | 5800  | 5600  | 5400 | 5200 | 5000 | 4500 | 4000 | 3500 | 3000 | 2900 |
| ARDY 50U/4.Ex | 7900                                                 | 7700  | 7500  | 7300 | 7100 | 6800 | 6300 | 5800 | 5100 | 4800 | 4500 |
| ARDY 56U/6.Ex | 8500                                                 | 8200  | 7900  | 7450 | 7000 | 7500 | 6000 | -    | -    | -    | -    |
| ARDY 63U/6.Ex | 11800                                                | 11000 | 10500 | 9800 | 9300 | 8600 | 7000 | -    | -    | -    | -    |

## DIMENSIONS

| MODEL         | DIMENSIONS/ mm |      |    |     |
|---------------|----------------|------|----|-----|
|               | □A             | □B   | C  | D   |
| ARDY 31U/4.Ex | 440            | 650  | 40 | 350 |
| ARDY 35U/4.Ex | 600            | 700  | 40 | 440 |
| ARDY 40U/4.Ex | 700            | 700  | 50 | 650 |
| ARDY 45U/4.Ex | 800            | 800  | 40 | 600 |
| ARDY 50U/4.Ex | 900            | 900  | 40 | 600 |
| ARDY 56U/6.Ex | 900            | 900  | 50 | 600 |
| ARDY 63U/6.Ex | 1000           | 1000 | 50 | 650 |

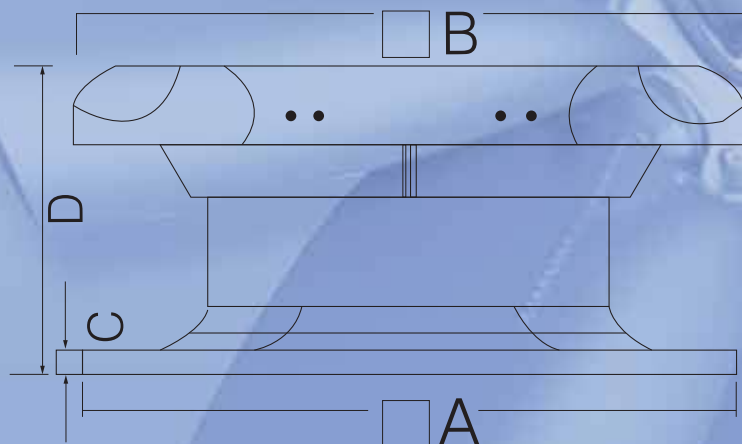

## AQC-ATEX Series

### Wall Type Axial Ex-Proof Fans



ATEX Certified wall mounted axial extractor fans with CEE ExII2G EX e explosion-proof. CEE ExII2G Ex d. Ex tc or Ex tb non-sparking motor for working in explosive atmospheres containing dust or gas.

#### FAN

- Motor-rotor air flow direction.
- Cast aluminium rotor.
- Anti-contact protective grille in accordance with standart UNE-EN ISO 12499 included in models 25 to 50
- Support frame in sheet steel with aluminium strip in rotor zone in accordance with standard EN-14986.

#### MOTOR

- ATEX- Certified. Ex e explosion proof. Ex d. Ex tc or Ex tb non-sparking class F motors with ball bearings.
- Three-phase 230/400V-50Hz and 400/690V-50Hz (powers higher than 4 Kw).
- Operating temperature -20°C + 55°C.

#### FINISH

- ATEX corrosion-proof with nonferric paint finish of polyester resin polymerised at 190°C previously degreased with phosphate-free nanotechnological treatment.

#### ON REQUEST

- Motors with built-in PTC.
- Special windings for different voltages and frequencies.
- ATEX construction for different categories.
- Extractor fans with 2-speed motors.
- Single-phase Ex-d non-sparking motors.

#### TECHNICAL SPECIFICATIONS

| MODEL     | MAX. AIRFLOW (m <sup>3</sup> /h) | WATT | SOUND (dBA) | AMPER | RPM (dk) | PRICE  |
|-----------|----------------------------------|------|-------------|-------|----------|--------|
| AQC 25-4T | 1301                             | 0.12 | 63          | 0,74  | 1.400    | 680 €  |
| AQC 31-4T | 2422                             | 0.12 | 66          | 0,74  | 1.400    | 700 €  |
| AQC 35-4T | 3544                             | 0.12 | 70          | 0,74  | 1.400    | 773 €  |
| AQC 40-4T | 5179                             | 0.25 | 75          | 1,20  | 1.400    | 1100 € |
| AQC 45-4T | 7276                             | 0.37 | 80          | 1,50  | 1.400    | 1210 € |
| AQC 50-4T | 10185                            | 0.55 | 83          | 1,70  | 1.400    | 1310 € |

## AIR FLOW PERFORMANCE DATA

| MODEL     | AIR FLOW PERFORMANCE DATA / PA / (m <sup>3</sup> /h) |      |      |      |      |      |      |      |      |      |      |
|-----------|------------------------------------------------------|------|------|------|------|------|------|------|------|------|------|
|           | 10                                                   | 30   | 50   | 70   | 90   | 110  | 130  | 150  | 170  | 190  | 210  |
| AQC 25-4T | 1200                                                 | 1000 | 760  | 450  | 250  | -    | -    | -    | -    | -    | -    |
| AQC 31-4T | 2100                                                 | 2000 | 1600 | 1100 | 450  | -    | -    | -    | -    | -    | -    |
| AQC 35-4T | 3400                                                 | 3070 | 2700 | 2200 | 1800 | 1000 | -    | -    | -    | -    | -    |
| AQC 40-4T | 5060                                                 | 4900 | 4530 | 4100 | 3500 | 2100 | 1850 | 1460 | 1200 | 1050 | -    |
| AQC 45-4T | 7200                                                 | 7000 | 6600 | 6100 | 5620 | 5000 | 4730 | 4340 | 3620 | 2100 | 1500 |
| AQC 50-4T | 10200                                                | 9920 | 9300 | 8600 | 8000 | 6900 | 6400 | 5920 | 5000 | 3200 | 2400 |

## DIMENSIONS

| MODEL     | DIMENSIONS / mm |     |       |     |       |    |      |      |     |  |
|-----------|-----------------|-----|-------|-----|-------|----|------|------|-----|--|
|           | A               | B   | C     | D   | E     | G  | H    | J    | K   |  |
| AQC 25-4T | 330             | 275 | 262   | 260 | 236,5 | 11 | 56   | 8.5  | 310 |  |
| AQC 31-4T | 400             | 336 | 310,5 | 308 | 245.5 | 11 | 65   | 10.5 | 380 |  |
| AQC 35-4T | 465             | 390 | 362.5 | 360 | 256.5 | 11 | 76   | 10.5 | 450 |  |
| AQC 40-4T | 532             | 452 | 412.5 | 410 | 297.5 | 11 | 97.5 | 10.5 | 500 |  |
| AQC 45-4T | 596             | 504 | 462.5 | 460 | 315.5 | 11 | 105  | 10.5 | 560 |  |
| AQC 50-4T | 665             | 562 | 516,5 | 514 | 325.5 | 11 | 115  | 10.5 | 640 |  |

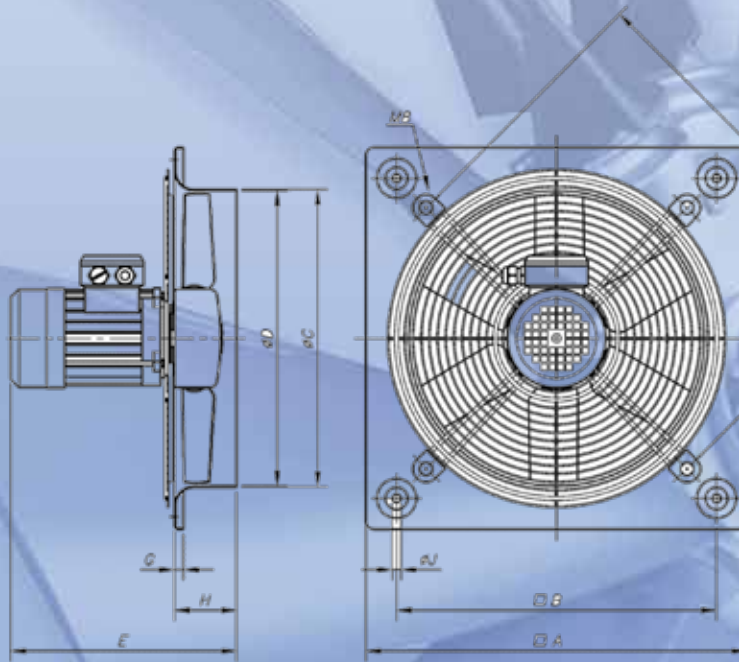

**AIT - ATEX Series**  
Inline Type Axial Ex-Proof



**FAN**

- Tubular casing made of sheet steel with aluminium strip in rotor zone in accordance with standard EN-14986.
- Cast aluminium rotor.
- With inspection hatch.
- Motor-rotor air direction.

**MOTOR**

- Atex-Certified Ex-e explosion-proof, Ex-d, Ex-tc or Ex-tb non-sparking class F motors with ball bearings.
- Three phase 230/400V-50Hz.

**FINISH**

- ATEX corrosion-proof with nonferric paint finish of polyester resin polymerised at 190°C previously degreased with phosphate-free nanotechnological treatment

**TECHNICAL SPECIFICATIONS**

| MODEL         | MAX. AIR FLOW (m <sup>3</sup> /h) | WATT | SOUND (dBA) | AMPER | RPM (dk) | PRICE  |
|---------------|-----------------------------------|------|-------------|-------|----------|--------|
| AIT 35-4T     | 3100                              | 0.12 | 57          | 3,10  | 1.230    | 748 €  |
| AIT 35-2T     | 5750                              | 0.37 | 57          | 2,73  | 1.310    | 1090 € |
| AIT 40-2T-1,5 | 8750                              | 1.10 | 60          | 3,93  | 1.300    | 1200 € |
| AIT 45-2T-2   | 10300                             | 1.50 | 65          | 6,00  | 1.320    | 1285 € |
| AIT 45-2T-3   | 12800                             | 2.20 | 67          | 9,35  | 1.140    | 1500 € |
| AIT 56-4T-2   | 15300                             | 1.50 | 61          | 7,00  | 930      | 1645 € |

**AIR FLOW PERFORMANCE DATA**

| MODEL         | AIR FLOW PERFORMANCE DATA / PA / (m <sup>3</sup> /h) |       |       |       |      |      |      |      |      |      |      |
|---------------|------------------------------------------------------|-------|-------|-------|------|------|------|------|------|------|------|
|               | 50                                                   | 100   | 150   | 200   | 250  | 300  | 350  | 400  | 450  | 500  | 550  |
| AIT 35-4T     | 2300                                                 | 1380  | -     | -     | -    | -    | -    | -    | -    | -    | -    |
| AIT 35-2T     | 5200                                                 | 5050  | 4530  | 4080  | 3530 | 3060 | 2200 | -    | -    | -    | -    |
| AIT 40-2T-1,5 | 8150                                                 | 7700  | 6900  | 5960  | 5210 | 4200 | 3620 | 3230 | -    | -    | -    |
| AIT 45-2T-2   | 10050                                                | 9820  | 9510  | 8400  | 8020 | 7030 | 6030 | 5020 | 4010 | 3700 | 2210 |
| AIT 45-2T-3   | 12300                                                | 11950 | 11600 | 10810 | 9980 | 9100 | 7380 | 6610 | 5150 | 3820 | 2250 |
| AIT 56-4T-2   | 14200                                                | 13120 | 10020 | 7030  | 4010 | 2220 | -    | -    | -    | -    | -    |

DIMENSIONS

| MODEL         | DIMENSIONS / mm |     |     |     |    |         |
|---------------|-----------------|-----|-----|-----|----|---------|
|               | ØA              | ØB  | D   | E   | ØJ | N       |
| AIT 35-4T     | 425             | 395 | 355 | 230 | 10 | 8 x 45  |
| AIT 35-2T     | 425             | 395 | 355 | 230 | 10 | 8 x 45  |
| AIT 40-2T-1,5 | 490             | 450 | 410 | 320 | 12 | 8 x 45  |
| AIT 45-2T-2   | 540             | 500 | 460 | 360 | 12 | 8 x 45  |
| AIT 45-2T-3   | 540             | 500 | 460 | 360 | 12 | 8 x 45  |
| AIT 56-4T-2   | 660             | 620 | 560 | 400 | 12 | 12 x 30 |
| AIT 63-4T-2   | 730             | 790 | 640 | 430 | 12 | 12 x 30 |
| AIT 71-4T-3   | 810             | 770 | 710 | 500 | 12 | 16 x 30 |

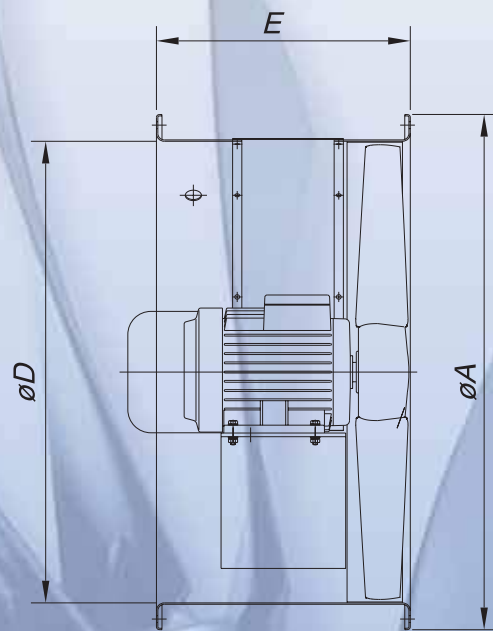
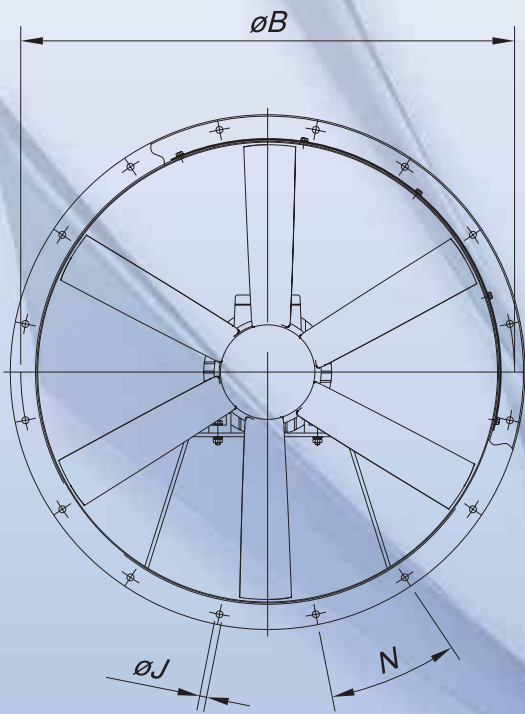

## PRF Series

### Rectangular Type Ex-proof Fans



#### FAN

- Tubular casing made of sheet steel with aluminium strip in rotor zone in accordance with standard EN-14986.
- Impeller with reaction blades in extremely robust sheet steel.
- Non-sparking inlet ring made of copper or aluminium.

#### MOTOR

- ATEX-Certified Ex-e explosion-proof, Ex-d, Ex-tc or Ex-tb non-sparking class F motors with ball bearings.
- Three phase 230/400V-50Hz.

#### FINISH

- ATEX corrosion-proof with nonferric paint finish of polyester resin polymerised at 190°C previously degreased with phosphate-free nanotechnological treatment

#### ON REQUEST

- Motors with built-in PTC.
- Special windings for different voltages and frequencies.
- ATEX construction for different categories.
- Construction entirely of stainless steel.

#### TECHNICAL SPECIFICATIONS

| MODEL        | MAX. AIR FLOW (m <sup>3</sup> /h) | WATT | SOUND (dBA) | RPM (dk) | DIMENSIONS | PRICE  |
|--------------|-----------------------------------|------|-------------|----------|------------|--------|
| PRF 20F/4.Ex | 1200                              | 0,54 | 82          | 1450     | 50 x 30    | 1060 € |
| PRF 22F/4.Ex | 1900                              | 1,00 | 81          | 1450     | 50 x 25    | 1470 € |
| PRF 25F/4.Ex | 2400                              | 1,50 | 82          | 1450     | 50 x 30    | 1707 € |
| PRF 28F/4.Ex | 3500                              | 3,00 | 87          | 1450     | 60 x 30    | 2180 € |
| PRF 28F/6.Ex | 2600                              | 1,00 | 76          | 960      | 60 x 30    | 2060 € |
| PRF 31F/4.Ex | 4500                              | 4,00 | 89          | 1450     | 60 x 35    | 2355 € |
| PRF 31F/6.Ex | 3500                              | 1,50 | 77          | 960      | 60 x 35    | 2475 € |
| PRF 35F/4.Ex | 4900                              | 2,50 | 87          | 1450     | 70 x 40    | 3060 € |



AIR PERFORMANCE DATA

| MODEL        | AIR PERFORMANCE DATA/ PA / (m <sup>3</sup> /h) |      |      |      |      |      |      |      |      |
|--------------|------------------------------------------------|------|------|------|------|------|------|------|------|
|              | 0                                              | 50   | 100  | 150  | 200  | 250  | 300  | 350  | 400  |
| PRF 20F/4.Ex | 1200                                           | 1100 | 1000 | 800  | 700  | -    | -    | -    | -    |
| PRF 22F/4.Ex | 1900                                           | 1800 | 1650 | 1550 | 1400 | 1200 | -    | -    | -    |
| PRF 25F/4.Ex | -                                              | 2400 | 2300 | 2200 | 1950 | 1750 | 1500 | -    | -    |
| PRF 28F/4.Ex | -                                              | -    | 3500 | 3250 | 3000 | 2800 | 2600 | 2400 | 2200 |
| PRF 28F/6.Ex | 2600                                           | 2500 | 2250 | 1900 | 1500 | -    | -    | -    | -    |
| PRF 31F/4.Ex | -                                              | -    | -    | -    | 4500 | 4250 | 4000 | 3750 | 3500 |
| PRF 31F/6.Ex | 3500                                           | 3100 | 2900 | 2500 | 2000 | -    | -    | -    | -    |
| PRF 35F/4.Ex | 4900                                           | 4500 | 4250 | 4000 | 3500 | 3000 | -    | -    | -    |



## RDY Series

Centrifugal Roof Type  
Ex-proof Fan

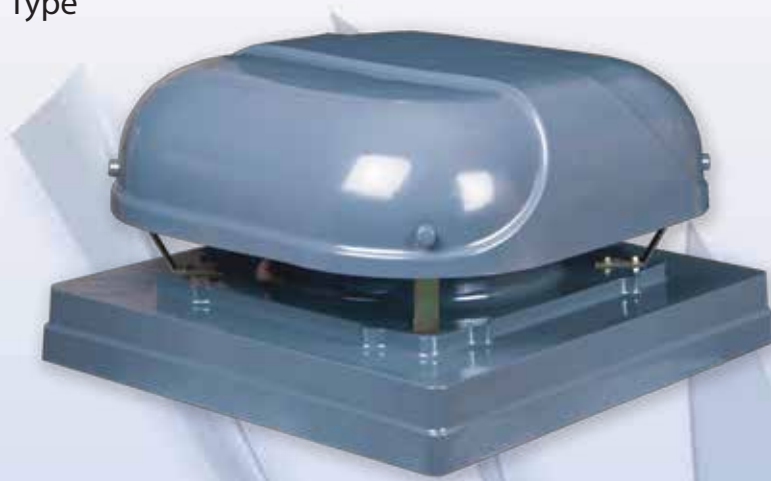

Centrifugal roof-mounted extractor fans with horizontal air outlet and aluminium rain cap. ATEX Certification and CEE ExII2G Ex-d non-sparking motor for working in explosive atmospheres.

### FAN

- Support base in galvanised sheet steel with brass intake nozzle in accordance with standard EN-14986
- Impeller with reaction blades made of galvanised sheet steel.
- Bird control grille.
- Aluminium rain cap.

### MOTOR

- ATEX- Certified. Ex e explosion proof. Ex d. Ex tc or Ex tb non-sparking class F motors with ball bearings.
- Three-phase 230/400V-50Hz and 400/690V-50Hz (powers higher than 4 Kw).
- Maximum temperature of air to be carried -20°C + 120°C.

### FINISH

- Corrosion-proof galvanised sheet steel and aluminium.

### ON REQUEST

- Motors with built-in PTC.
- Special windings for different voltages and frequencies.
- ATEX construction for different categories.
- Single-phase Ex-d non-sparking motors.

## TECHNICAL SPECIFICATIONS

| MODEL    | MAX. AIR FLOW (m <sup>3</sup> /h) | WATT | SOUND (dBA) | AMPER | RPM (dk) | PRICE  |
|----------|-----------------------------------|------|-------------|-------|----------|--------|
| 28E/4.Ex | 1700                              | 0,15 | 70          | 0,80  | 1450     | 1295 € |
| 31E/4.Ex | 2300                              | 0,22 | 70          | 1,20  | 1450     | 1355 € |
| 35E/4.Ex | 3500                              | 0,32 | 75          | 2,10  | 1450     | 1529 € |
| 40E/4.Ex | 4500                              | 0,55 | 78          | 2,20  | 1450     | 1647 € |
| 45E/4.Ex | 6800                              | 1,00 | 83          | 2,20  | 1450     | 2000 € |
| 50E/4.Ex | 9000                              | 1,60 | 86          | 3,00  | 1450     | 2300 € |
| 56E/6.Ex | 7800                              | 0,65 | 74          | 4,00  | 1450     | 2940 € |
| 63E/6.Ex | 11000                             | 1,14 | 87          | 7,50  | 1450     | 3530 € |
| 71E/6.Ex | 17000                             | 2,60 | 86          | 1,10  | 1450     | 4415 € |

## AIRFLOW PERFORMANCE DATA

| MODEL        | AIR FLOW PERFORMANCE DATA/ PA / (m <sup>3</sup> /h) |       |       |       |       |       |       |       |       |
|--------------|-----------------------------------------------------|-------|-------|-------|-------|-------|-------|-------|-------|
|              | 0                                                   | 50    | 100   | 150   | 200   | 250   | 300   | 350   | 400   |
| RDY 28E/4.Ex | 1700                                                | 1500  | 1250  | 1000  | -     | -     | -     | -     | -     |
| RDY 31E/4.Ex | 2300                                                | 2150  | 2000  | 1500  | -     | -     | -     | -     | -     |
| RDY 35E/4.Ex | 3500                                                | 3100  | 2800  | 2400  | 2000  | -     | -     | -     | -     |
| RDY 40E/4.Ex | 4500                                                | 4100  | 3800  | 3500  | 3100  | 2800  | 2500  | -     | -     |
| RDY 45E/4.Ex | 6800                                                | 6500  | 6200  | 5900  | 5500  | 5100  | 4800  | 4300  | 4000  |
| RDY 50E/4.Ex | 9000                                                | 8750  | 8500  | 8250  | 8000  | 7500  | 7000  | 6500  | 6000  |
| RDY 56E/6.Ex | 7800                                                | 7000  | 6000  | 5000  | 4000  | -     | -     | -     | -     |
| RDY 63E/6.Ex | 11000                                               | 10000 | 9000  | 8000  | 7000  | 6000  | -     | -     | -     |
| RDY 71E/6.Ex | 17000                                               | 16000 | 15000 | 14000 | 13000 | 12000 | 11000 | 10500 | 10000 |

## DIMENSIONS

| MODEL        | DIMENSIONS / mm |      |    |     |
|--------------|-----------------|------|----|-----|
|              | □A              | □B   | C  | D   |
| RDY 28E/4.Ex | 440             | 550  | 40 | 350 |
| RDY 31E/4.Ex | 440             | 650  | 40 | 350 |
| RDY 35E/4.Ex | 600             | 700  | 40 | 440 |
| RDY 40E/4.Ex | 700             | 700  | 50 | 650 |
| RDY 45E/4.Ex | 800             | 800  | 40 | 600 |
| RDY 50E/4.Ex | 900             | 900  | 40 | 600 |
| RDY 56E/6.Ex | 900             | 900  | 50 | 600 |
| RDY 63E/6.Ex | 1000            | 1000 | 50 | 650 |
| RDY 71E/6.Ex | 1250            | 1250 | 50 | 650 |

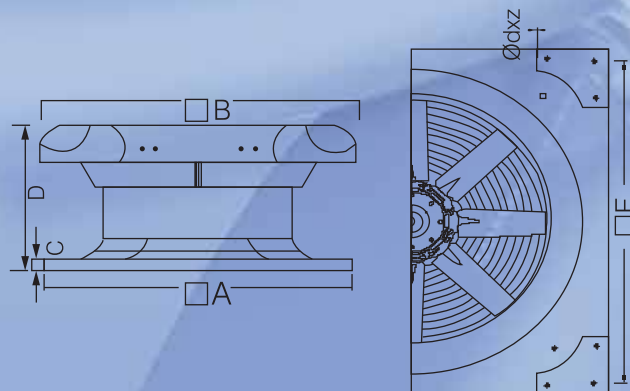

ACCESSORIES



If the car park has significant queuing areas for vehicles, refer to section 4.6 in AS1668.2:2012

#### Appendix

#### AS/NZS1668.2 - 2012 Calculation Factors

#### Parking Usage Factor (P)

| Use of car park                | Parking usage factor (P) |
|--------------------------------|--------------------------|
| Residential                    | 0.3                      |
| Commercial                     | 0.5                      |
| Retail/food and drink services | 0.7                      |
| Entertainment/sports centres   | 1.0                      |
| Vehicle Depots                 | 2.4                      |

#### Vehicle Type Factor (T)

| Use of car park Parking       | Vehicle type factor (T) |
|-------------------------------|-------------------------|
| No special vehicle population | 1.0                     |
| Diesel vehicles               | 2.4                     |
| LPG vehicles                  | 1.0                     |
| CNG vehicles                  | 1.0                     |
| Electric powered vehicles     | 0.1                     |
| Motorcycles                   | 0.25                    |

#### Staff Usage/Exposure Factor (E & F)

| Parking procedure                                                                                                | Staff exposure factor (E) | Staff usage factor (F)                                                          |
|------------------------------------------------------------------------------------------------------------------|---------------------------|---------------------------------------------------------------------------------|
| No special procedures (self-parking), any staff in separate enclosure ventilated in accordance with Clause 4.2.2 | 1                         | 1                                                                               |
| Self-parking stack parking, any staff in separate enclosure ventilated in accordance with Clause 4.2.2           | 1                         | $1 + 0.1 \times \text{No. of car spaces without immediate access to driveway}$  |
| No special procedures (self-parking), staff located in car parking enclosure                                     | 1.8                       | 2                                                                               |
| Self parking stack parking, staff located in car parking enclosure                                               | 1.8                       | $2 + 0.25 \times \text{No. of car spaces without immediate access to driveway}$ |
| Attendant parking no stack parking                                                                               | 1.8                       | $2.5 \times \text{No. of attendants}$                                           |
| Attendant parking stack parking                                                                                  | 1.8                       | $3.5 \times \text{No. of attendants}$                                           |
| Mechanical stack parking                                                                                         | 1.8                       | $2 \times \text{No. of car engines operating at any one time}$                  |

## P Series

Anticorrosive Single-inlet  
Centrifugal Fans  
Made Of Polypropylene



### FAN

- Polypropylene casing.
- Impeller with forward-curved blades made of polypropylene.

### MOTOR

- IE3 efficiency motors for powers equal to or greater than 0,18 Kw except single-phase 2-speed and 8-pole.
- Class F motors with ball bearings and IP55 protection.
- Three-phase 230/400V-50Hz and 400/690V-50Hz
- Maximum temperature of air to be carried: -20°C + 70°C.

### FINISH

- Anticorrosive in plastic material.

### TECHNICAL SPECIFICATIONS

| MODEL | MAX. AIR FLOW (m <sup>3</sup> /h) | WATT | PRESSURE (PA) | DUCT DIMENSION (Ø) | RPM (dk) | PRICE  |
|-------|-----------------------------------|------|---------------|--------------------|----------|--------|
| P160  | 1300                              | 0.18 | 400           | Ø160               | 1450     | 493 €  |
| P200  | 2200                              | 0.37 | 700           | Ø200               | 2900     | 640 €  |
| P225  | 3400                              | 0.75 | 1300          | Ø225               | 2900     | 743 €  |
| P250  | 4300                              | 1.50 | 1300          | Ø250               | 2900     | 950 €  |
| P280  | 6800                              | 2.20 | 1700          | Ø280               | 2900     | 1058 € |
| P315  | 4600                              | 0.55 | 500           | Ø315               | 1450     | 1221 € |
| P355  | 10000                             | 3    | 1700          | Ø355               | 2900     | 2182 € |

### AIR FLOW PERFORMANCE DATA

| MODEL | AIR FLOW PERFORMANCE DATA / PA / (m <sup>3</sup> /h) |      |      |      |       |      |      |      |      |      |      |      |
|-------|------------------------------------------------------|------|------|------|-------|------|------|------|------|------|------|------|
|       | 100                                                  | 200  | 300  | 400  | 500   | 600  | 700  | 800  | 1000 | 1300 | 1500 | 1700 |
| P160  | 1100                                                 | 1000 | 600  | 350  | -     | -    | -    | -    | -    | -    | -    | -    |
| P200  | -                                                    | 2100 | 2000 | 1800 | 1600  | 1400 | 1000 | -    | -    | -    | -    | -    |
| P225  | -                                                    | -    | -    | 3400 | 3200  | 3000 | 2900 | 2700 | 2200 | 1000 | -    | -    |
| P250  | -                                                    | -    | -    | 4300 | 4200  | 4000 | 3800 | 3500 | 2500 | 1450 | -    | -    |
| P280  | -                                                    | -    | -    | -    | 6800  | 6600 | 6400 | 6000 | 5400 | 4500 | 3500 | 2150 |
| P315  | -                                                    | 4600 | 4100 | 3300 | 2500  | -    | -    | -    | -    | -    | -    | -    |
| P355  | -                                                    | -    | -    | -    | 10000 | 9900 | 9700 | 9400 | 8850 | 7000 | 5900 | 4200 |

## DIMENSIONS

| MODEL | DIMENSIONS / mm |    |     |     |     |     |     |     |     |
|-------|-----------------|----|-----|-----|-----|-----|-----|-----|-----|
|       | A               | C  | D   | E   | H   | I   | L   | P   | Q   |
| P160  | 140             | 35 | 160 | 160 | 250 | 150 | 190 | 100 | 140 |
| P200  | 173             | 35 | 200 | 185 | 310 | 190 | 210 | 100 | 140 |
| P225  | 208             | 40 | 225 | 195 | 350 | 210 | 240 | 120 | 190 |
| P250  | 240             | 40 | 250 | 200 | 410 | 230 | 290 | 150 | 230 |
| P280  | 260             | 40 | 280 | 237 | 445 | 270 | 290 | 150 | 250 |
| P315  | 290             | 40 | 315 | 252 | 495 | 295 | 240 | 170 | 250 |
| P355  | 324             | 40 | 355 | 287 | 550 | 330 | 415 | 270 | 340 |

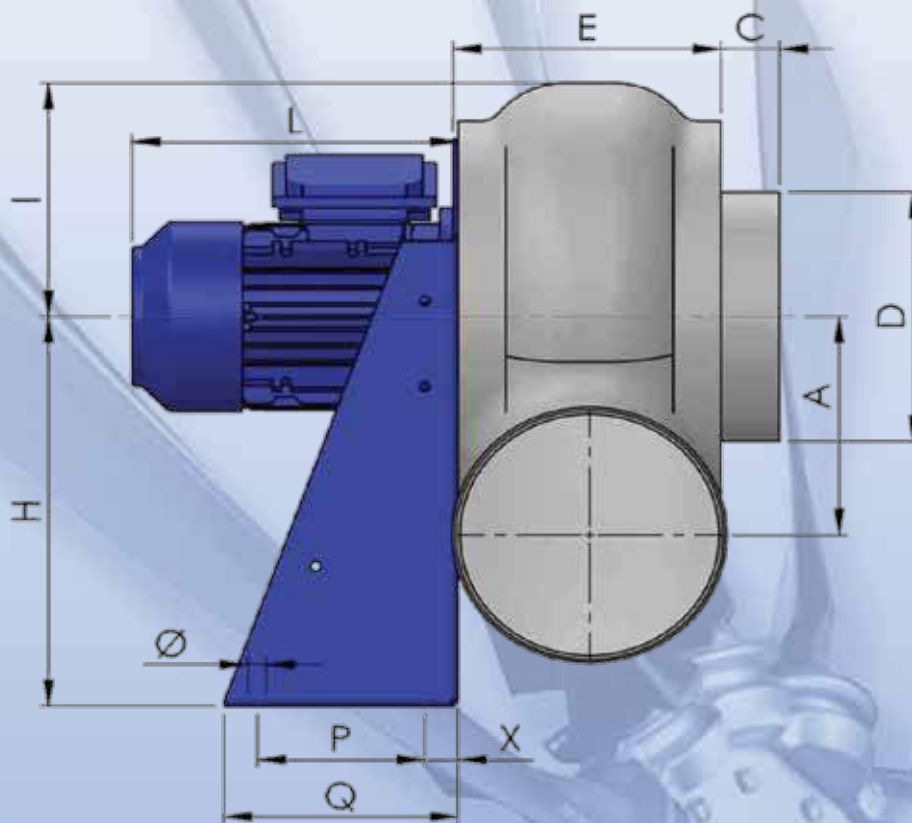

**CDR Series**  
Centrifugal Single-inlet  
Direct Drive Fans



Medium pressure single inlet centrifugal fans fitted with backward-curved blade impellers with a self-cleaning effect specially designed for paint booths. IE3 efficiency motors for powers equal to or greater than 0,55 Kw except single-phase 2-speed and 8-pole. Class F motors with ball bearings and IP55 protection. Maximum temperature of air to be carried -20°C + 120°C.

TECHNICAL SPECIFICATIONS

| MODEL      | MAX. AIR FLOW (m <sup>3</sup> /h) | WATT  | PRESSURE (Pa) | DUCT DIMENSIONS(Ø) | RPM(dk) | PRICE  |
|------------|-----------------------------------|-------|---------------|--------------------|---------|--------|
| CDR 32A-4T | 3000                              | 0,55  | 400           | Ø250               | 1450    | 433 €  |
| CDR 40A-4T | 4000                              | 0,75  | 500           | Ø320               | 1450    | 500 €  |
| CDR 40B-4T | 5000                              | 0,75  | 550           | Ø320               | 1450    | 533 €  |
| CDR 40C-4T | 6000                              | 1,10  | 600           | Ø320               | 1450    | 566 €  |
| CDR 45A-4T | 7000                              | 1,10  | 650           | Ø350               | 1450    | 670 €  |
| CDR 45B-4T | 8000                              | 1,50  | 750           | Ø350               | 1450    | 770 €  |
| CDR 45C-4T | 9000                              | 2,20  | 800           | Ø350               | 1450    | 835 €  |
| CDR 50A-4T | 10000                             | 2,20  | 850           | Ø400               | 1450    | 870 €  |
| CDR 50B-4T | 12000                             | 3,00  | 950           | Ø400               | 1450    | 950 €  |
| CDR 55A-4T | 14000                             | 4,00  | 1050          | Ø450               | 1450    | 1266 € |
| CDR 55B-4T | 16000                             | 4,00  | 1100          | Ø450               | 1450    | 1335 € |
| CDR 63A-4T | 18000                             | 5,50  | 1200          | Ø500               | 1450    | 1533 € |
| CDR 63B-4T | 20000                             | 7,50  | 1300          | Ø500               | 1450    | 1940 € |
| CDR 63C-4T | 22000                             | 7,50  | 1400          | Ø500               | 1450    | 2000 € |
| CDR 70A-4T | 26000                             | 11,00 | 1600          | Ø650               | 1450    | 2370 € |
| CDR 70B-4T | 30000                             | 15,00 | 1800          | Ø650               | 1450    | 2750 € |
| CDR 80A-4T | 40000                             | 18,50 | 2000          | Ø745               | 1450    | 3300 € |
| CDR 80B-4T | 50000                             | 22,00 | 2250          | Ø745               | 1450    | 4000 € |
| CDR 70B-6T | 20000                             | 5,50  | 450           | Ø650               | 1000    | 3350 € |
| CDR 80C-6T | 30000                             | 7,50  | 500           | Ø745               | 1000    | 3835 € |



AIR FLOW PERFORMANCE DATA

| MODEL      | AIR FLOW PERFORMANCE DATA/ PA / (m <sup>3</sup> /h) |      |       |       |       |       |       |       |       |       |       |       |
|------------|-----------------------------------------------------|------|-------|-------|-------|-------|-------|-------|-------|-------|-------|-------|
|            | 100                                                 | 200  | 300   | 400   | 500   | 600   | 700   | 800   | 900   | 1000  | 1100  | 1200  |
| CDR 32A-4T | 3000                                                | 2500 | 1700  | -     | -     | -     | -     | -     | -     | -     | -     | -     |
| CDR 40A-4T | 4000                                                | 3200 | 2700  | 1500  | -     | -     | -     | -     | -     | -     | -     | -     |
| CDR 40B-4T | 5000                                                | 4300 | 3800  | 2200  | 1800  | -     | -     | -     | -     | -     | -     | -     |
| CDR 40C-4T | 6000                                                | 5400 | 4600  | 3000  | 2400  | -     | -     | -     | -     | -     | -     | -     |
| CDR 45A-4T | 7000                                                | 6500 | 6000  | 5400  | 4200  | 2400  | -     | -     | -     | -     | -     | -     |
| CDR 45B-4T | -                                                   | -    | 8000  | 6700  | 5700  | 4200  | 2700  | -     | -     | -     | -     | -     |
| CDR 45C-4T | -                                                   | -    | 9000  | 8000  | 7300  | 5700  | 5800  | 3000  | -     | -     | -     | -     |
| CDR 50A-4T | -                                                   | -    | 10000 | 9000  | 8400  | 7300  | 6000  | 3360  | -     | -     | -     | -     |
| CDR 50B-4T | -                                                   | -    | 12000 | 11000 | 9600  | 8400  | 7500  | 6000  | 4000  | -     | -     | -     |
| CDR 55A-4T | -                                                   | -    | 14000 | 13700 | 13000 | 12000 | 11500 | 11000 | 8400  | 5400  | -     | -     |
| CDR 55B-4T | -                                                   | -    | -     | -     | 16000 | 14000 | 13000 | 12000 | 9800  | 8400  | 6000  | -     |
| CDR 63A-4T | -                                                   | -    | -     | -     | 18000 | 17300 | 17000 | 16800 | 15600 | 15000 | 13000 | 10000 |
| CDR 63B-4T | -                                                   | -    | -     | -     | -     | 20000 | 18000 | 19000 | 16800 | 16000 | 14000 | 12000 |
| CDR 63C-4T | -                                                   | -    | -     | -     | -     | -     | 22000 | 24500 | 19000 | 17000 | 14000 | 11500 |
| CDR 70A-4T | -                                                   | -    | -     | -     | -     | -     | 26000 | 31000 | 24500 | 24000 | 23000 | 22000 |
| CDR 70B-4T | -                                                   | -    | -     | -     | -     | -     | 33000 | 40000 | 31000 | 30000 | 27000 | 25000 |
| CDR 80A-4T | -                                                   | -    | -     | -     | -     | -     | -     | 50000 | 40000 | 39000 | 38000 | 37000 |
| CDR 80B-4T | -                                                   | -    | -     | -     | -     | -     | -     | -     | 50000 | 47000 | 45000 | 43000 |

| MODEL      | AIR FLOW PERFORMANCE DATA/ PA / (m <sup>3</sup> /h) |       |       |       |       |       |       |       |       |       |       |      |
|------------|-----------------------------------------------------|-------|-------|-------|-------|-------|-------|-------|-------|-------|-------|------|
|            | 1300                                                | 1400  | 1500  | 1600  | 1700  | 1800  | 1900  | 2000  | 2100  | 2200  | 2300  | 2400 |
| CDR 32A-4T | -                                                   | -     | -     | -     | -     | -     | -     | -     | -     | -     | -     | -    |
| CDR 40A-4T | -                                                   | -     | -     | -     | -     | -     | -     | -     | -     | -     | -     | -    |
| CDR 40B-4T | -                                                   | -     | -     | -     | -     | -     | -     | -     | -     | -     | -     | -    |
| CDR 40C-4T | -                                                   | -     | -     | -     | -     | -     | -     | -     | -     | -     | -     | -    |
| CDR 45A-4T | -                                                   | -     | -     | -     | -     | -     | -     | -     | -     | -     | -     | -    |
| CDR 45B-4T | -                                                   | -     | -     | -     | -     | -     | -     | -     | -     | -     | -     | -    |
| CDR 45C-4T | -                                                   | -     | -     | -     | -     | -     | -     | -     | -     | -     | -     | -    |
| CDR 50A-4T | -                                                   | -     | -     | -     | -     | -     | -     | -     | -     | -     | -     | -    |
| CDR 50B-4T | -                                                   | -     | -     | -     | -     | -     | -     | -     | -     | -     | -     | -    |
| CDR 55A-4T | -                                                   | -     | -     | -     | -     | -     | -     | -     | -     | -     | -     | -    |
| CDR 55B-4T | -                                                   | -     | -     | -     | -     | -     | -     | -     | -     | -     | -     | -    |
| CDR 63A-4T | 8400                                                | -     | -     | -     | -     | -     | -     | -     | -     | -     | -     | -    |
| CDR 63B-4T | 10000                                               | 9000  | -     | -     | -     | -     | -     | -     | -     | -     | -     | -    |
| CDR 63C-4T | 9000                                                | -     | -     | -     | -     | -     | -     | -     | -     | -     | -     | -    |
| CDR 70A-4T | 20000                                               | 17000 | 14000 | -     | -     | -     | -     | -     | -     | -     | -     | -    |
| CDR 70B-4T | 24000                                               | 20000 | 19700 | 19000 | 15000 | 11000 | -     | -     | -     | -     | -     | -    |
| CDR 80A-4T | 36000                                               | 35000 | 34000 | 32000 | 30000 | 29000 | 27000 | 24000 | 18000 | -     | -     | -    |
| CDR 80B-4T | 40000                                               | 38000 | 37000 | 36000 | 34000 | 32000 | 30000 | 26000 | 24000 | 22000 | 16000 | -    |

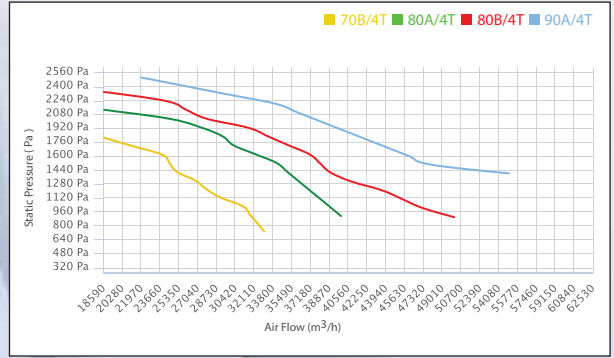
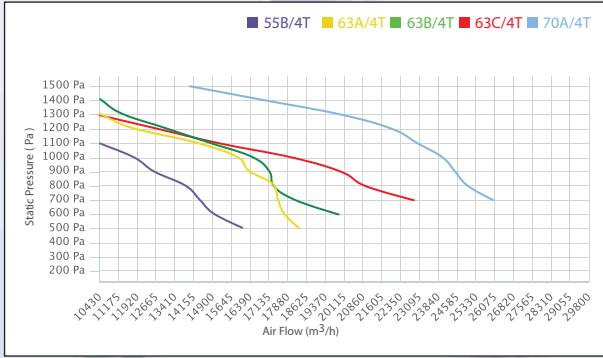
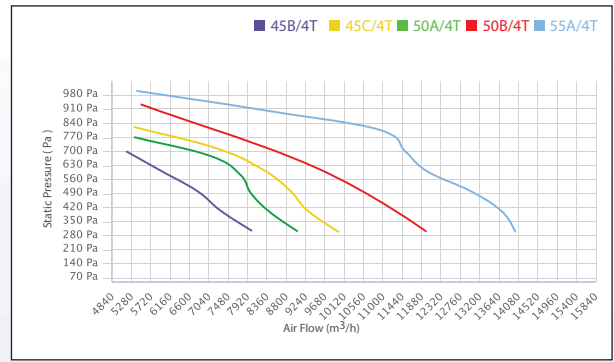
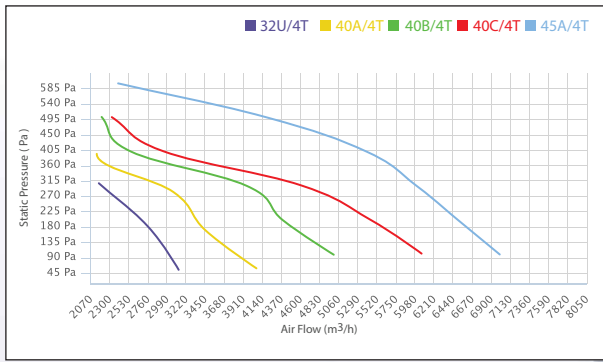

DIMENSIONS

| MODEL  | DIMENSIONS / mm |      |      |     |
|--------|-----------------|------|------|-----|
|        | A               | B    | C    | ØD  |
| CDR 32 | 600             | 600  | 525  | 250 |
| CDR 40 | 700             | 700  | 600  | 320 |
| CDR 45 | 700             | 700  | 605  | 350 |
| CDR 50 | 790             | 790  | 705  | 400 |
| CDR 55 | 870             | 870  | 770  | 450 |
| CDR 63 | 1000            | 1000 | 900  | 500 |
| CDR 70 | 1100            | 1100 | 950  | 650 |
| CDR 80 | 1230            | 1230 | 1260 | 745 |

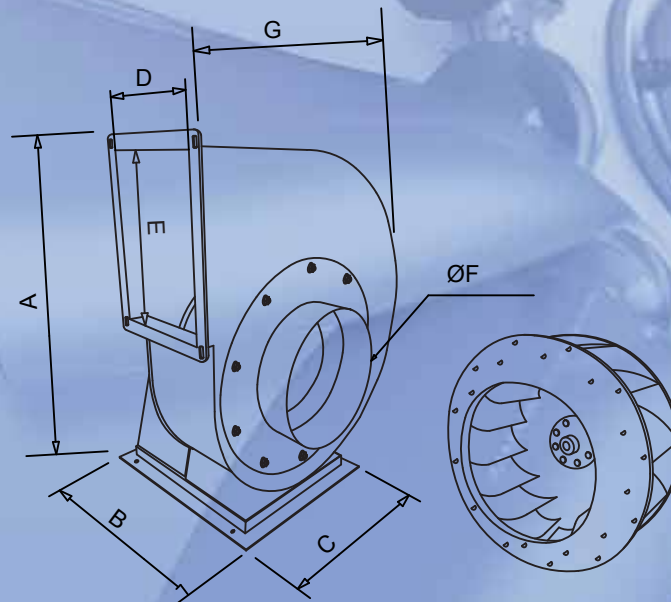

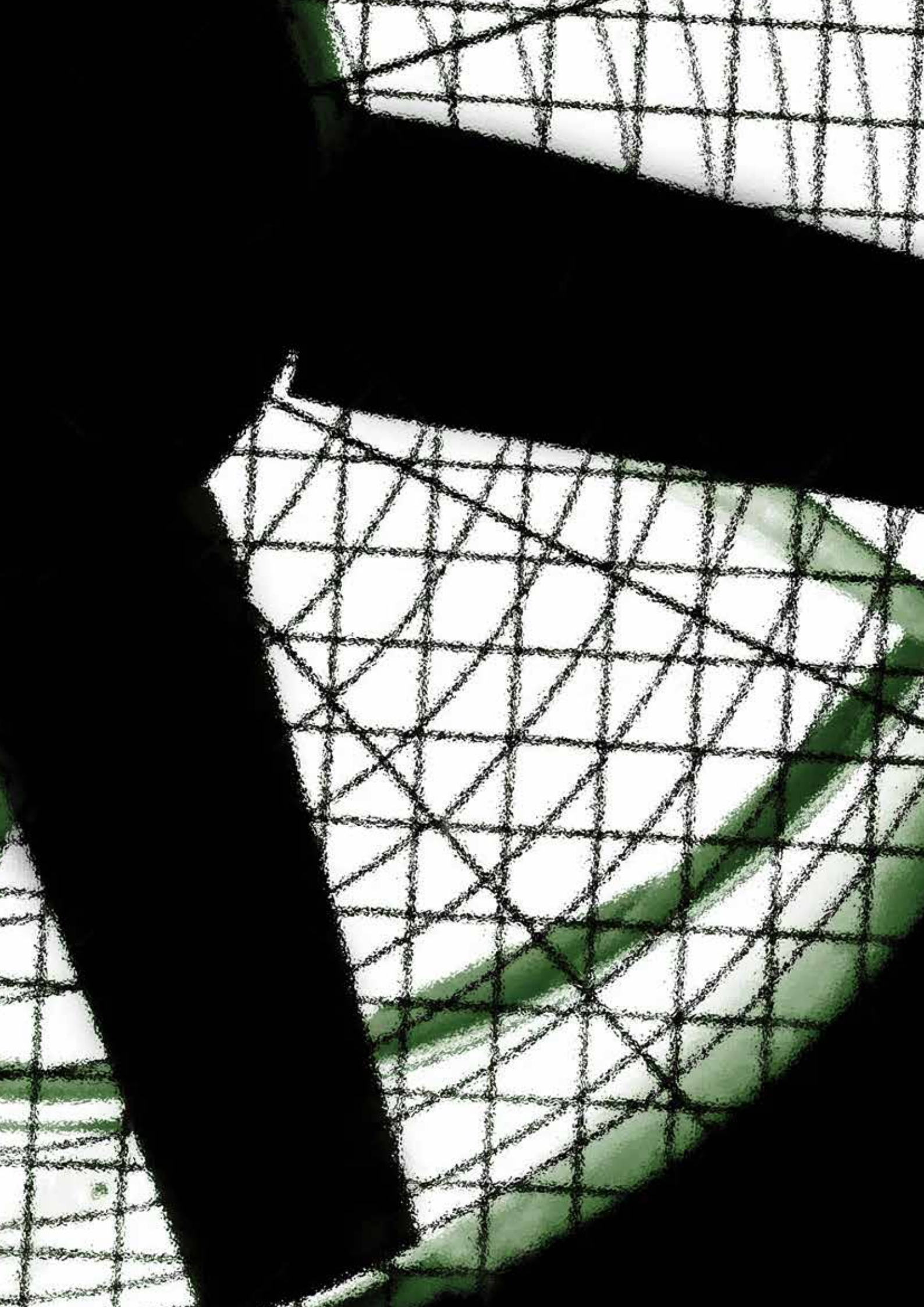

**AXF Series**  
Axial Type Smoke  
Extract Fans



**FAN**

- Tubular sheet steel casing.
- Variable angle rotors made of cast aluminium.
- Approved in accordance with standard EN 12101-3

**MOTOR**

- Class H motors for S1 continuous operation and S2 emergency use with ball bearings. IP55 protection and 1 or 2 speeds depending on model.
- IE2 or IE3 efficiency motors depending on model except 2 speed and 8 poles.
- Three-phase 230/400V-50Hz and 400/690V-50HZ (powers higher than 3 Kw).
- Maximum temperature of air to be carried: S1 continuous operation -20°C +55°C S2 operation 300°C/2h. 400°C/2h. Also suitable for hot climates with temperatures up to 50°C. S2 operation 300°C/2h. 400°C/2h.

**FINISH**

- Anticorrosive finish of polyester resin polymerised at 190°C previously degreased with phosphate-free nanotechnological treatment.

**ON REQUEST**

- Motor-rotor air flow direction.
- Rotors 100% reversible.

## TECHNICAL SPECIFICATIONS

| MODEL       | MAX. AIR FLOW (m <sup>3</sup> /h) | WATT  | SOUND (dBA) | RPM (dk) | PRICE  |
|-------------|-----------------------------------|-------|-------------|----------|--------|
| 25U/2.F...  | 2150                              | 0,25  | 81          | 2950     | -      |
| 28U/2.F...  | 3000                              | 0,37  | 83          | 2950     | -      |
| 31U/2.F...  | 4000                              | 0,55  | 85          | 2950     | -      |
| 35U/2.F...  | 5500                              | 1,10  | 89          | 2950     | 770 €  |
| 40U/2.F...  | 8000                              | 1,50  | 92          | 2950     | 802 €  |
| 45U/2.F...  | 11000                             | 3,00  | 95          | 2950     | 1000 € |
| 50U/2.F...  | 14000                             | 4,00  | 96          | 2950     | 1135 € |
| 56U/2.F...  | 17780                             | 5,50  | 97          | 2950     | 1474 € |
| 63U/2.F...  | 22700                             | 7,50  | 98          | 2950     | 1663 € |
| 71U/4.F...  | 20000                             | 2,20  | 89          | 1450     | 1200 € |
| 71U/4.F...  | 24000                             | 4,00  | 91          | 1450     | 1275 € |
| 80U/4.F...  | 28000                             | 5,50  | 92          | 1450     | 1650 € |
| 80U/4.F...  | 33000                             | 7,50  | 96          | 1450     | 1730 € |
| 90U/4.F...  | 29000                             | 3,00  | 89          | 1450     | 1410 € |
| 90U/4.F...  | 40000                             | 7,50  | 96          | 1450     | 1800 € |
| 100U/4.F... | 43000                             | 7,50  | 93          | 1450     | 1950 € |
| 100U/4.F... | 50000                             | 11,00 | 97          | 1450     | 2100 € |
| 100U/4.F... | 59000                             | 15,00 | 100         | 1450     | 2850 € |
| 100U/4.F... | 55000                             | 11,00 | 99          | 1450     | 2230 € |
| 112U/4.F... | 64000                             | 15,00 | 99          | 1450     | 2550 € |
| 112U/4.F... | 80000                             | 25,00 | 104         | 1450     | 3300 € |
| 112U/6.F... | 55000                             | 7,50  | 95          | 950      | 2150 € |
| 125U/4.F... | 64000                             | 11,00 | 94          | 1450     | 2520 € |
| 125U/4.F... | 61000                             | 15,00 | 95          | 1450     | 2775 € |
| 125U/4.F... | 88000                             | 30,00 | 101         | 1450     | 4200 € |
| 125U/4.F... | 105000                            | 37,00 | 105         | 1450     | 4950 € |

AIR FLOW PERFORMANCE DATA

| MODEL       | AIR FLOW PERFORMANCE DATA / PA / (m <sup>3</sup> /h) |       |       |        |        |        |        |       |       |       |       |       |
|-------------|------------------------------------------------------|-------|-------|--------|--------|--------|--------|-------|-------|-------|-------|-------|
|             | 100                                                  | 150   | 200   | 250    | 300    | 400    | 500    | 600   | 700   | 800   | 900   | 1000  |
| 25U/2.F...  | 2150                                                 | 2000  | 1700  | 1270   | -      | -      | -      | -     | -     | -     | -     | -     |
| 28U/2.F...  | 3000                                                 | 2820  | 2500  | 2250   | 1780   | -      | -      | -     | -     | -     | -     | -     |
| 31U/2.F...  | -                                                    | 4000  | 3600  | 3300   | 3000   | -      | -      | -     | -     | -     | -     | -     |
| 35U/2.F...  | -                                                    | 5500  | 5235  | 5000   | 4750   | 4100   | -      | -     | -     | -     | -     | -     |
| 40U/2.F...  | -                                                    | -     | 8000  | 7600   | 7300   | 6550   | 5710   | 3510  | -     | -     | -     | -     |
| 45U/2.F...  | -                                                    | -     | -     | 11000  | 10400  | 9700   | 8750   | 7300  | -     | -     | -     | -     |
| 50U/2.F...  | -                                                    | -     | -     | 14000  | 13600  | 13000  | 11900  | 10550 | 8900  | -     | -     | -     |
| 56U/2.F...  | -                                                    | -     | -     | -      | 17780  | 16770  | 15680  | 14400 | 12700 | 10500 | -     | -     |
| 63U/2.F...  | -                                                    | -     | -     | -      | 22700  | 21600  | 20350  | 18900 | 17200 | 15400 | -     | -     |
| 71U/4.F...  | 20000                                                | 20000 | 17500 | 15000  | 13000  | -      | -      | -     | -     | -     | -     | -     |
| 71U/4.F...  | -                                                    | -     | 24000 | 19000  | 16000  | -      | -      | -     | -     | -     | -     | -     |
| 80U/4.F...  | 28000                                                | 28000 | 26500 | 25000  | 20000  | 13000  | -      | -     | -     | -     | -     | -     |
| 80U/4.F...  | -                                                    | -     | 33000 | 28000  | 25000  | 20000  | -      | -     | -     | -     | -     | -     |
| 90U/4.F...  | 29000                                                | 29000 | 26000 | 23500  | 20000  | 16000  | -      | -     | -     | -     | -     | -     |
| 90U/4.F...  | -                                                    | -     | 40000 | 37000  | 34000  | 27500  | -      | -     | -     | -     | -     | -     |
| 100U/4.F... | 43000                                                | 43000 | 41000 | 39000  | 37500  | 32000  | 25000  | 20000 | -     | -     | -     | -     |
| 100U/4.F... | -                                                    | -     | 50000 | 48000  | 46500  | 42000  | 35600  | 25000 | -     | -     | -     | -     |
| 100U/4.F... | -                                                    | -     | -     | -      | 59000  | 52000  | 45000  | 30000 | -     | -     | -     | -     |
| 100U/4.F... | -                                                    | -     | -     | 55000  | 53000  | 47000  | 40000  | -     | -     | -     | -     | -     |
| 112U/4.F... | -                                                    | -     | 64000 | 61500  | 59000  | 57000  | 51000  | 46000 | 40000 | -     | -     | -     |
| 112U/4.F... | -                                                    | -     | -     | -      | -      | 80000  | 76000  | 69000 | 60000 | -     | -     | -     |
| 112U/6.F... | 55000                                                | 55000 | 50000 | 45000  | 40000  | -      | -      | -     | -     | -     | -     | -     |
| 125U/4.F... | 64000                                                | 64000 | 62000 | 57000  | 53000  | 35000  | -      | -     | -     | -     | -     | -     |
| 125U/4.F... | 61000                                                | 61000 | 60000 | 58000  | 56500  | 55000  | 52000  | 50000 | 45000 | 40000 | 35000 | -     |
| 125U/4.F... | -                                                    | -     | -     | 88000  | 85000  | 83000  | 79000  | 76000 | 71000 | 66000 | 60000 | -     |
| 125U/4.F... | -                                                    | -     | -     | 105000 | 105000 | 100000 | 100000 | 94000 | 90000 | 84000 | 76000 | 70000 |

DIMENSIONS

| MODEL    | DIMENSIONS/ mm  |      |      |         |     |   |     |
|----------|-----------------|------|------|---------|-----|---|-----|
|          | ØD <sub>i</sub> | ØTK  | ØDA  | ZxØd    | L   | S | hf  |
| AXF 25U  | 252             | 295  | 332  | 8 x 10  | 500 | 2 | 176 |
| AXF 28U  | 283             | 322  | 363  | 8 x 10  | 500 | 2 | 192 |
| AXF 31U  | 315             | 356  | 395  | 8 x 10  | 500 | 2 | 208 |
| AXF 35U  | 355             | 395  | 435  | 8 x 10  | 500 | 2 | 228 |
| AXF 40U  | 400             | 450  | 480  | 8 x 12  | 500 | 2 | 270 |
| AXF 45U  | 450             | 500  | 530  | 8 x 12  | 500 | 3 | 295 |
| AXF 50U  | 500             | 560  | 590  | 12 x 12 | 500 | 3 | 320 |
| AXF 56U  | 560             | 620  | 660  | 14 x 12 | 500 | 3 | 350 |
| AXF 63U  | 630             | 690  | 730  | 14 x 12 | 500 | 3 | 385 |
| AXF 71U  | 710             | 770  | 810  | 16 x 14 | 500 | 3 | 425 |
| AXF 80U  | 800             | 860  | 900  | 16 x 14 | 500 | 3 | 470 |
| AXF 90U  | 900             | 970  | 1000 | 16 x 15 | 500 | 4 | 550 |
| AXF 100U | 1000            | 1070 | 1100 | 16 x 15 | 500 | 4 | 600 |
| AXF 112U | 1120            | 1190 | 1220 | 24 x 15 | 750 | 4 | 760 |
| AXF 125U | 1250            | 1320 | 1370 | 24 x 15 | 750 | 6 | 725 |



## ZXF Series Axial Jet Fan



### FAN

- Single-direction or reversible ventilation unit consisting of a fan, silencers, deflectors and brackets, certified for smoke extraction in accordance with standard EN-12101-3:2002/AC:2006.
- Turnable impellers in cast aluminium designed for optimum thrust.
- Protection guard against contacts, in accordance with standard UNE-EN ISO 12499:2010 in single-direction models
- Deflectors to increase airflow range, on the impeller side. Reversible models are fitted with deflectors on both sides.
- High effective silencers with thermal and acoustic insulation.
- Airflow direction from motor to impeller or 100% reversible.

### MOTOR

- Class H motors ongoing use S1 and S2 emergency use with ball bearings. IP55 protection and 2 speed.
- Three-phase 400V-50Hz
- Maximum temperature of air to be carried: S1 continuous operation -20°C +55°C S2 operation 300°C/2h. 400°C/2h. Also suitable for hot climates with temperatures up to 50°C. S2 operation 300°C/2h. 400°C/2h.

### FINISH

- Anticorrosive finish of polyester resin polymerised at 190°C anti-corrosive galvanised sheet steel

### ON REQUEST

- Different thrust performance from that indicated.

## TECHNICAL SPECIFICATIONS

| MODEL        | MAX. AIR FLOW (m <sup>3</sup> /h) | WATT      | SOUND (dBA) | RPM (dk)  | THRUST (N) | PRICE  |
|--------------|-----------------------------------|-----------|-------------|-----------|------------|--------|
| ZXF 31U/2-4T | 4800/2400                         | 0,80/0,20 | 52/37       | 2850/1450 | 35/9       | 1000 € |
| ZXF 35U/2-4T | 7200/3600                         | 1,50/0,37 | 52/37       | 2850/1450 | 58/14      | 1095 € |
| ZXF 40U/2-4T | 9800/4900                         | 2,20/0,55 | 53/38       | 2850/1450 | 75/18      | 1183 € |
| ZXF 45U/2-4T | 12800/6400                        | 2,20/0,55 | 58/43       | 2850/1450 | 87/25      | 1275 € |

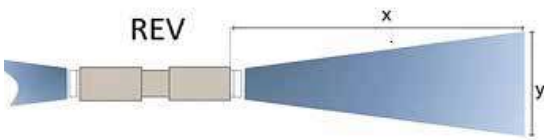

## AIR FLOW PERFORMANCE DATA

|                                                                                   |                     |             |                     |               |
|-----------------------------------------------------------------------------------|---------------------|-------------|---------------------|---------------|
|  | Outlet Distance (X) | 25          | m                   | <b>ZXF 31</b> |
|                                                                                   | Outlet Distance (y) | 11          | m                   |               |
|                                                                                   | Air Flow            | 4.800/2.400 | (m <sup>3</sup> /h) |               |
|                                                                                   | Thrust              | 35/9        | N                   |               |

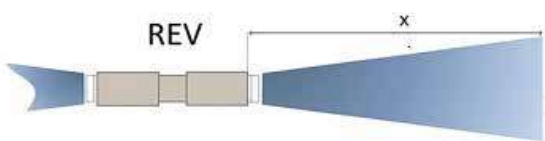
|                                                                                   |                     |             |                     |               |
|-----------------------------------------------------------------------------------|---------------------|-------------|---------------------|---------------|
|  | Outlet Distance (X) | 30          | m                   | <b>ZXF 35</b> |
|                                                                                   | Outlet Distance (y) | 13          | m                   |               |
|                                                                                   | Air Flow            | 6.000/3.000 | (m <sup>3</sup> /h) |               |
|                                                                                   | Thrust              | 58/14       | N                   |               |

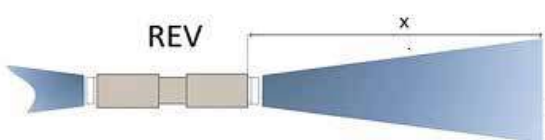
|                                                                                   |                     |             |                     |               |
|-----------------------------------------------------------------------------------|---------------------|-------------|---------------------|---------------|
|  | Outlet Distance (X) | 40          | m                   | <b>ZXF 40</b> |
|                                                                                   | Outlet Distance (y) | 17          | m                   |               |
|                                                                                   | Air Flow            | 9.800/4.900 | (m <sup>3</sup> /h) |               |
|                                                                                   | Thrust              | 75/18       | N                   |               |

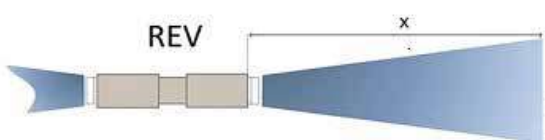
|                                                                                    |                     |              |                     |               |
|------------------------------------------------------------------------------------|---------------------|--------------|---------------------|---------------|
|  | Outlet Distance (X) | 45           | m                   | <b>ZXF 45</b> |
|                                                                                    | Outlet Distance (y) | 19           | m                   |               |
|                                                                                    | Air Flow            | 12.800/6.400 | (m <sup>3</sup> /h) |               |
|                                                                                    | Thrust              | 87/25        | N                   |               |

## DIMENSIONS

| MODEL        | DIMENSIONS / mm |        |         |         |        |
|--------------|-----------------|--------|---------|---------|--------|
|              | A (mm)          | C (mm) | DI (mm) | DA (mm) | H (mm) |
| ZXF 31U/2-4T | 600             | 1700   | 315     | 415     | 100    |
| ZXF 35U/2-4T | 600             | 1700   | 355     | 450     | 100    |
| ZXF 40U/2-4T | 800             | 2100   | 400     | 500     | 100    |
| ZXF 45U/2-4T | 800             | 2100   | 450     | 550     | 100    |

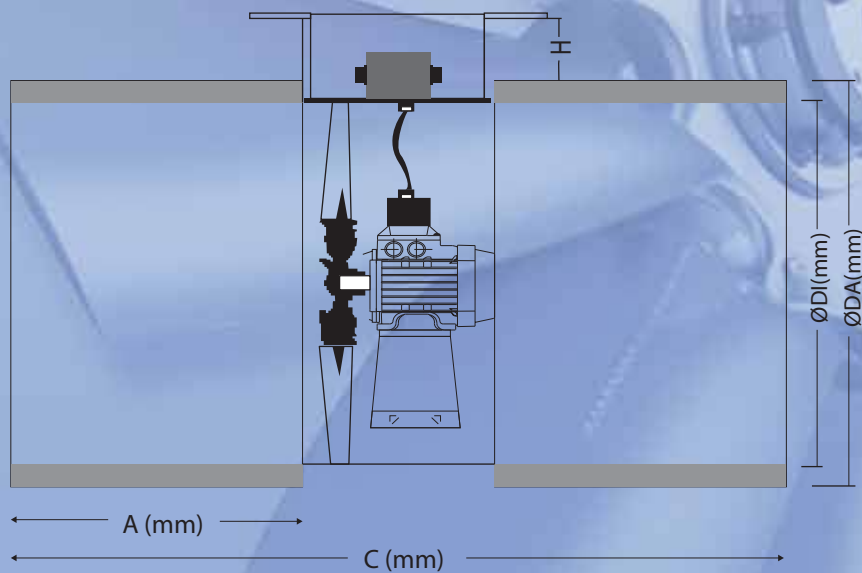

## ZXR Series Centrifugal Jet Fan

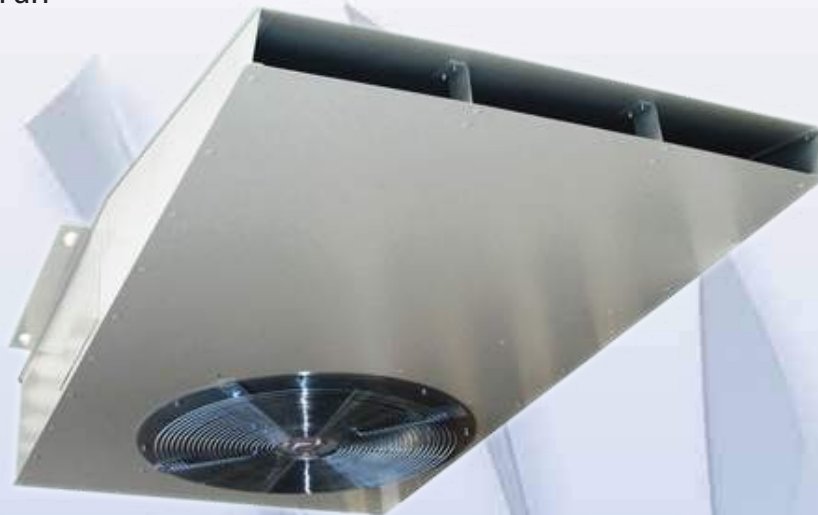

Long-range 300°C/2h and 400°C/2h centrifugal induction jet fans for use in fire risk zones with a low profile.

### fAN

- Sheet steel casing
- Impeller with reaction blades in extremely robust sheet steel.
- IAT series safety switch built into the fan
- Support feet included.

### MOTOR

- Class H motors ongoing use S1 and S2 emergency use with ball bearings. IP55 protection and with 1 or 2 speeds depending on models.
- Three-phase 400V-50Hz
- Maximum temperature of air to be carried: S1 continuous operation -20°C +55°C S2 operation 300°C/2h. 400°C/2h. Also suitable for hot climates with temperatures up to 50°C. S2 operation 300°C/2h. 400°C/2h.

### FINISH

- Anticorrosive finish of polyester resin polymerised at 190°C anti-corrosive galvanised sheet steel

### ON REQUEST

- Different thrust performance from that indicated.

### TECHNICAL SPECIFICATIONS

| MODEL        | MAX. AIRFLOW (m <sup>3</sup> /h) | WATT      | SOUND (dBA) | RPM (dk) | THRUST (N) | PRICE  |
|--------------|----------------------------------|-----------|-------------|----------|------------|--------|
| ZXR 50-4/8T  | 6860/3430                        | 1,10/0,37 | 86          | 1430/705 | 63/28      | 1154 € |
| ZXR 75-4/8T  | 9350/3675                        | 2,20/0,55 | 93          | 1430/700 | 75/19      | -      |
| ZXR 100-4/8T | 11950/5975                       | 4,00/1,00 | 97          | 1450/780 | 100/25     | -      |

## AIR FLOW PERFORMANCE DATA

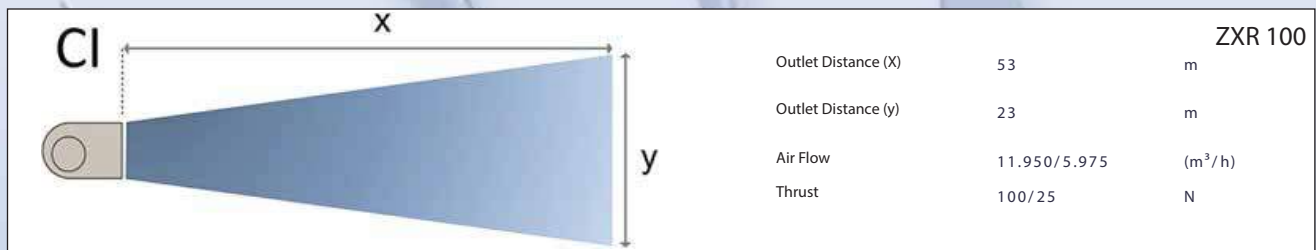
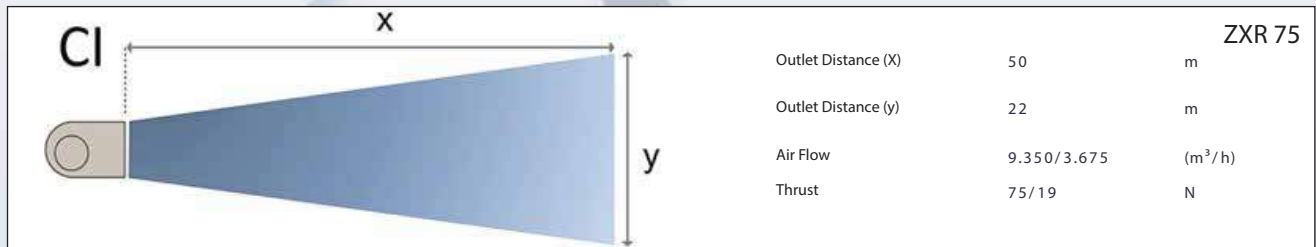
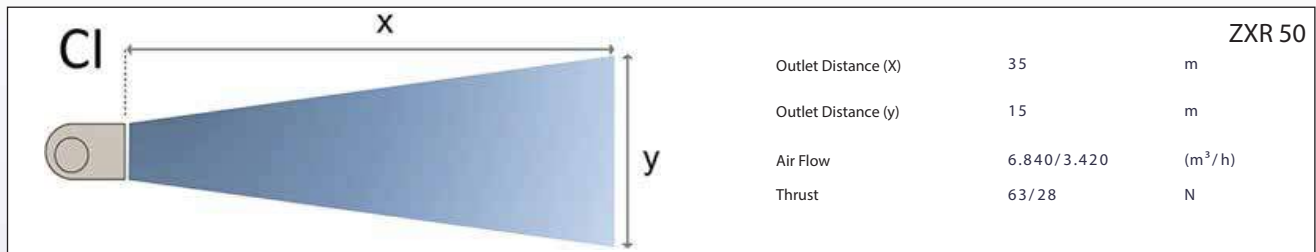

## DIMENSIONS

| MODEL   | DIMENSIONS / mm |         |        |         |         |         |         |          |
|---------|-----------------|---------|--------|---------|---------|---------|---------|----------|
|         | A (mm)          | B (mm)  | C (mm) | V2 (mm) | V1 (mm) | X1 (mm) | X2 (mm) | Kxn (mm) |
| ZXR 50  | 1275,50         | 956     | 282,50 | 575     | 727     | 504     | 504     | 12 x 26  |
| ZXR 75  | 1377            | 1065,50 | 351    | 620,50  | 783     | 557,50  | 559,50  | 12 x 26  |
| ZXR 100 | 1800            | 1161    | 389    | 975     | 846     | 627,50  | 581     | 12 x 26  |

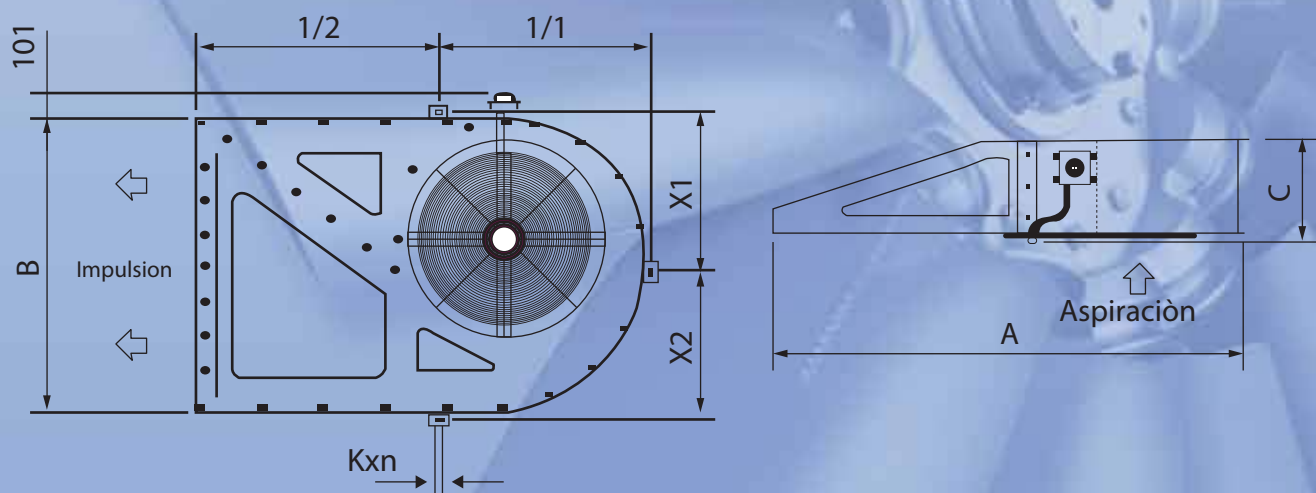

## CHR Series Heat Recovery Units



Low profile heat recovery ventilators for fitting in false ceiling. Incorporate BY-PASS energy efficient with heat recovery efficiency of up to 82%.

### FINISH

- Galvanised steel structure.
- Anti-condensation foam coating.
- Interior in light expanded polypropylene for low noise emission levels.
- Low profile for fitting in false ceiling.

### FEATURES

- Counterflow heat exchanger.
- Incorporate 100% automatic BY-PASS except REB-15.
- Three speed energy efficient EC fans.
- Side access for maintenance.
- Operation compatible 50/60Hz.
- G4 Filters.
- 3-speed SI-VOC + HUMEDAD selector switch supplied as an accessory.

### TECHNICAL SPECIFICATIONS

| MODEL  | MAX. AIRFLOW (m <sup>3</sup> /h) | WATT     | PRESSURE (Pa) | RECOMMENDED ELECTRIC HEATER CAPACITY (kw) | PRICE  |
|--------|----------------------------------|----------|---------------|-------------------------------------------|--------|
| AHRV-1 | 1500                             | 147 x 2  | 250           | 3                                         | 1305 € |
| AHRV-2 | 2800                             | 420 x 2  | 350           | 6                                         | 1685 € |
| AHRV-3 | 4300                             | 500 x 2  | 300           | 9                                         | 2070 € |
| AHRV-4 | 6000                             | 736 x 2  | 300           | 12                                        | 2670 € |
| AHRV-5 | 7000                             | 1100 x 2 | 300           | 15                                        | 2830 € |

AIR FLOW PERFORMANCE DATA

| MODEL | AIR FLOW PERFORMANCE DATA/ PA / (m <sup>3</sup> /h) |      |      |      |      |      |      |
|-------|-----------------------------------------------------|------|------|------|------|------|------|
|       | 0                                                   | 100  | 150  | 200  | 250  | 300  | 350  |
| CHR-1 | 1500                                                | 1460 | 1350 | 1030 | 500  | -    | -    |
| CHR-2 | 2800                                                | 2700 | 2650 | 2600 | 2500 | 2100 | 1100 |
| CHR-3 | -                                                   | 4000 | 3800 | 3000 | -    | -    | -    |
| CHR-4 | -                                                   | -    | 6000 | 5800 | 5100 | 4200 | -    |
| CHR-5 | -                                                   | -    | 7000 | 6600 | 6000 | 5000 | -    |

DIMENSIONS

| MODEL | DIMENSIONS / mm    |      |     |     |                            |     |     |     |             |
|-------|--------------------|------|-----|-----|----------------------------|-----|-----|-----|-------------|
|       | PRODUCT DIMENSIONS |      |     |     | LINE CONNECTION DIMENSIONS |     |     |     | WEIGHT (kg) |
|       | A                  | B    | C   | ØD  | X1                         | X2  | X3  | X4  |             |
| CHR-1 | 750                | 950  | 380 | 250 | 250                        | 150 | 175 | 150 | 55          |
| CHR-2 | 900                | 1200 | 440 | 300 | 300                        | 175 | 200 | 175 | 80          |
| CHR-3 | 1000               | 1400 | 530 | 350 | 200                        | 215 | 325 | 215 | 101         |
| CHR-4 | 1150               | 1650 | 630 | 400 | 265                        | 250 | 400 | 250 | 140         |
| CHR-5 | 1150               | 1650 | 630 | 400 | 265                        | 250 | 400 | 250 | 140         |

